



Austrian Institute of Construction Engineering
Schenkenstrasse 4 | T+43 1 533 65 50
1010 Vienna | Austria | F+43 1 533 64 23
www.oib.or.at | mail@oib.or.at



European Technical Assessment

ETA-13/0796
of 15.12.2017

General part

Technical Assessment Body issuing the European Technical Assessment

Österreichisches Institut für Bautechnik (OIB)
Austrian Institute of Construction Engineering

Trade name of the construction product

Simpson Strong-Tie® screws ESCR/ESCR-S,
ESCRC/ESCRC-S, ESCRS, ESCRFTC/
ESCRFTC-S, ESCRFT/ESCRFT-S, ESCRFTZ/
ESCRFTZ-S, ESCRHD/HRD, ESCRT2R/
ESCRT2R-S, ESCRH/ESCRH-S and SSTA

Product family to which the construction product belongs

Screws for use in timber constructions

Manufacturer

SIMPSON STRONG-TIE® GmbH
Hubert-Vergölst-Straße 6-14
61231 Bad Nauheim
Germany

Manufacturing plant

Simpson Strong-Tie® Manufacturing Facility

This European Technical Assessment contains

47 pages including 12 Annexes, which form an
integral part of this assessment.

This European Technical Assessment is issued in accordance with Regulation (EU) No 305/2011, on the basis of

European Assessment Document
EAD 130118-00-0603 "Screws for use in timber
constructions".

This European Technical Assessment replaces

European technical approval ETA-13/0796 with
validity from 28.06.2013 to 04.11.2017.

Remarks

Translations of the European Technical Assessment in other languages shall fully correspond to the original issued document and should be identified as such.

Communication of this European Technical Assessment, including transmission by electronic means, shall be in full. However, partial reproduction may be made with the written consent of Österreichisches Institut für Bautechnik. Any partial reproduction has to be identified as such.

Specific parts

1 Technical description of the product

This European Technical Assessment¹ (ETA) applies to the screws for use in timber constructions “Simpson Strong-Tie® screws ESCR, ESCRC, ESCRS, ESCRFTC, ESCRFT/FTZ, ESCRHD/HRD, ESCRT2R, ESCRH and SSTA” made from hardened carbon steel as well as “Simpson Strong-Tie® screws ESCR-S, ESCRC-S, ESCRFTC-S, ESCRFT-S, ESCRFTZ-S, ESCRT2R-S and ESCRH-S” made from stainless steel. Simpson Strong-Tie® screws are self-tapping screws divided into a drill tip, optionally a compressor and/or cutting groove, thread, optionally a friction part, shank, and head of the screw. The screws from special carbon steel are anti-friction coated and are electrogalvanized and passivated (yellow or blue), provided with a zinc-nickel coating or hot-dip galvanized. The washers are made from carbon steel. Possible outer thread diameters as well as overall lengths for the Simpson Strong-Tie® screws are given in Table 1.

The screws and washers correspond to the specifications given from Annex 1 to Annex 8. The material characteristics, dimensions and tolerances of the product not indicated in these Annexes, are given in the technical file² of the European Technical Assessment.

Table 1: Possible outer thread diameter and overall length of screws

Type of screws	Outer thread diameter		Overall length	
	min.	max.	min.	max.
	mm	mm	mm	mm
ESCR/ESCR-S	6	10	20	500
ESCRC/ESCRC-S	4	10	20	500
ESCRS	4	6	20	300
ESCRFTC/ESCRFTC-S	6	12	20	1000
ESCRFT/ESCRFT-S ESCRFTZ/ESCRFTZ-S	6	12	20	1000
ESCRHD/HRD	8	12	20	500
ESCRT2R/ESCRT2R-S	8	8	120	600
ESCRH/ESCRH-S	6	12	20	120
SSTA	6	12	20	500

¹ The ETA-13/0796 was firstly issued in 2013 as European technical approval with validity from 28.06.2013 and amended and converted in 2017 to the European Technical Assessment ETA-13/0796 of 15.12.2017.

² The technical file of the European Technical Assessment is deposited at Österreichisches Institut für Bautechnik.

2 Specification of the intended use(s) in accordance with the applicable European Assessment Document

2.1 Intended use

The screws are used for connections in load bearing timber structures between wood-based members or between those members and steel members:

- Solid timber of softwood of strength class C14 or better and solid timber of hardwood of strength class D18 or better according to EN 338³ and EN 14081-1,
- Glued laminated timber and glued solid timber of softwood of strength class GL20 or better according to EN 14080 or glued laminated timber of hardwood according to European Technical Assessments or national provisions that apply on the installation site,
- Laminated veneer lumber LVL according to EN 14374,
- Cross laminated timber according to European Technical Assessments or national provisions that apply on the installation site.

The screws may be used for connecting the following wood-based panels to the timber members mentioned above:

- Laminated veneer lumber LVL according to EN 14374,
- Solid wood panels according to EN 13353 and EN 13986,
- Plywood according to EN 636 and EN 13986,
- Oriented strand boards, OSB, according to EN 300 and EN 13986,
- Particleboards according to EN 312 and EN 13986,
- Fibreboards according to EN 622-2, EN 622-3 and EN 13986,
- Cement-bonded particle boards according EN 634-1 and EN 13986 or European Technical Assessments or national provisions that apply on the installation site.

Compression and tension reinforcement perpendicular to the grain with fully threaded screws as well as shear reinforcement with fully threaded screws with a diameter $d \geq 8$ mm is allowed.

In addition, screws with $6 \text{ mm} \leq d \leq 12 \text{ mm}$ may be used for fixing of thermal insulation on roof constructions and walls of timber.

The product shall be subjected to static and quasi static actions only.

The product is intended to be used in service classes 1, 2 and 3 according to EN 1995-1-1. The scope of the screws regarding resistance to corrosion shall be defined according to national provisions that apply at the installation site considering environmental conditions.

Hot-dip galvanised screws with a minimum thickness of the zinc coating of $55 \mu\text{m}$ as well as screws made of stainless steel may be used in conditions defined by service class 3. The field of application of the screws made of stainless steel shall be defined according to EN 1993-1-4 or national provisions that apply at the installation site.

2.2 General assumptions

The screws for use in timber constructions are manufactured in accordance with the provisions of the European Technical Assessment using the manufacturing process as identified in the inspection of the manufacturing plant by Österreichisches Institut für Bautechnik and laid down in the technical file.

³ Reference documents are listed in Annex 12.

The manufacturer shall ensure that the requirements in accordance with the Clauses 1, 2 and 3 as well as with the Annexes of the European Technical Assessment are made known to those who are concerned with design and execution of the works.

Design

The European Technical Assessment only applies to the manufacture and use of the screws for use in timber constructions. Verification of stability of the works including application of loads on the products is not subject to the European Technical Assessment.

The following conditions shall be observed:

- Design of Simpson Strong-Tie® screws is carried under the responsibility of an engineer experienced in such products.
- Design of the works shall account for the protection of Simpson Strong-Tie® screws to maintain service classes 1 and 2 according to EN 1995-1-1 or national provisions that apply on the installation site.
- Simpson Strong-Tie® screws are installed correctly.

Design of the screws for use in timber constructions may be according to EN 1995-1-1, taking into account of Annex 9 to Annex 11 of the European Technical Assessment. Hereby, the outer thread diameter d is used as nominal diameter d or rather effective diameter d_{ef} and l_{ef} is the threaded part in the timber member including point.

Standards and regulations in force at the place of use shall be considered.

Packaging, transport, storage, maintenance, replacement and repair

Concerning product packaging, transport, storage, maintenance, replacement and repair it is the responsibility of the manufacturer to undertake the appropriate measures and to advise his clients on the transport, storage, maintenance, replacement and repair of the product as he considers necessary.

Installation

It is assumed that the product will be installed according to the manufacturer's instructions or (in absence of such instructions) according to the usual practice of the building professionals.

The screws are either screwed into the wood-based member without pre-drilling or in predrilled holes with a diameter not exceeding the inner thread diameter. The screw holes in steel members shall be pre-drilled with an adequate diameter greater than the outer thread diameter.

Screws with an outer thread diameter $5 \text{ mm} \leq d \leq 12 \text{ mm}$ may be screwed into laminated veneer lumber LVL of beech or related products of hardwood with predrilling.

At least four screws shall be used in a connection with screws inserted in the timber member with an angle between screw axis and grain direction of less than 15° . The penetration length of the threaded part of the screw shall be at least $20 d$.

To ensure a proper installation for screws with lengths of more than 800 mm a guiding hole of $5 d$ is recommended.

For mounting of steel plates and wood-based panels the screw head must be placed on top of these members.

The structural members which are connected with Simpson Strong-Tie® screws shall

- be in accordance with Clause 2.1;
- ensure minimum spacing and edge distances in accordance with EN 1995-1-1 and Annex 10.

2.3 Working life/Durability

The provisions made in the European Technical Assessment (ETA) are based on an assumed intended working life of Simpson Strong-Tie® screws of 50 years, when installed in the works, provided that the screws are subject to appropriate installation, use and maintenance (see Clause 2.2). These provisions are based upon the current state of the art and the available knowledge and experience⁴.

The indications given as to the working life of the construction product cannot be interpreted as a guarantee neither given by the product manufacturer or his representative nor by EOTA nor by the Technical Assessment Body, but are regarded only as a means for choosing the appropriate products in relation to the expected economically reasonable working life of the works.

3 Performance of the product and reference to the methods used for its assessment

3.1 Essential characteristics of the product

Table 2: Essential characteristics of the product and product performance

No	Essential characteristic	Product performance
Basic requirement for construction works 1: Mechanical resistance and stability ¹⁾		
1	Dimensions	Annex 1 to Annex 8
2	Characteristic yield moment	Annex 9
3	Bending angle	Annex 9
4	Characteristic withdrawal parameter	Annex 9
5	Characteristic head pull-through parameter	Annex 9
6	Characteristic tensile strength	Annex 9
7	Characteristic yield strength	Annex 9
8	Characteristic torsional strength	Annex 9
9	Insertion moment	Annex 9
10	Spacing, end and edge distances of the screws and minimum thickness of the wood based material	Annex 10, if relevant
11	Slip modulus for mainly axially loaded screws	Annex 9
12	Durability against corrosion	3.1.1
Basic requirement for construction works 2: Safety in case of fire		
13	Reaction to fire	3.1.2
Basic requirement for construction works 4: Safety and accessibility in use		
14	Same as BWR 1	
¹⁾ These characteristics also relate to basic requirement 4 for construction works.		

⁴ The real working life of a product incorporated in a specific works depends on the environmental conditions to which that works is subject, as well as on the particular conditions of the design, execution, use and maintenance of that works. Therefore, it cannot be excluded that in certain cases the real working life of the product can also be shorter than the assumed working life.

3.1.1 Durability against corrosion

The product is intended to be used in service classes 1, 2 and 3 according to EN 1995-1-1.

The screws and washers made from carbon steel are electrogalvanized and yellow or blue passivated, coated with a zinc-nickel coating or hot-dip galvanized. The minimum thickness of the zinc coating of the screws is 5 µm and the minimum thickness of the zinc-nickel coating is 4 µm. The minimum thickness of the zinc coating of hot-dip galvanized screws is 55 µm.

Steel no. 1.4567 or 1.4578 or equivalent according to EN 10088-1 is used for screws made from stainless steel.

Durability of Simpson Strong-Tie® screws is in accordance with EN 1995-1-1 or national provisions that apply on the installation site.

3.1.2 Reaction to fire

Simpson Strong-Tie® screws are made from steel classified as Euroclass A1 in accordance with Commission Decision 96/603/EC, as amended by Commission Decision 2000/605/EC.

3.2 Assessment methods

3.2.1 General

The assessment of the essential characteristics in Clause 3.1 of the screws for use in timber constructions for the intended use, and in relation to the requirements for mechanical resistance and stability, for safety in case of fire and for safety and accessibility in use in the sense of the basic requirements for construction works № 1, 2 and 4 of Regulation (EU) № 305/2011 has been made in accordance with the European Assessment Document EAD 130118-00-0603, "Screws for use in timber constructions".

3.2.2 Identification

The European Technical Assessment for the screws for use in timber constructions is issued on the basis of agreed data that identify the assessed product. Changes to materials, to composition, to characteristics of the product, or to the production process could result in these deposited data being incorrect. Österreichisches Institut für Bautechnik should be notified before the changes are implemented, as an amendment of the European Technical Assessment is possibly necessary.

4 Assessment and verification of constancy of performance (thereinafter AVCP) system applied, with reference to its legal base

4.1 System of assessment and verification of constancy of performance

According to Commission Decision 97/176/EC the system of assessment and verification of constancy of performance to be applied to "Simpson Strong-Tie® screws" is System 3. System 3 is detailed in Commission Delegated Regulation (EU) № 568/2014 of 18 February 2014, Annex, 1.4., and provides for the following items

- (a) The manufacturer shall carry out factory production control.
- (b) The notified laboratory shall assess the performance on the basis of testing (based on sampling carried out by the manufacturer), calculation, tabulated values or descriptive documentation of the construction product.

4.2 AVCP for construction products for which a European Technical Assessment has been issued

Notified bodies undertaking tasks under System 3 shall consider the European Technical Assessment issued for the construction product in question as the assessment of the performance of that product. Notified bodies shall therefore not undertake the tasks referred to in point 4.1 (b).

5 Technical details necessary for the implementation of the AVCP system, as provided for in the applicable European Assessment Document

5.1 Tasks for the manufacturer

5.1.1 Factory production control

In the manufacturing plant the manufacturer shall establish and continuously maintain a factory production control. All procedures and specifications adopted by the manufacturer shall be documented in a systematic manner. The factory production control shall ensure the constancy of performances of Simpson Strong-Tie® screws with regard to the essential characteristics.

The manufacturer shall only use raw materials supplied with the relevant inspection documents as laid down in the control plan. The incoming raw materials shall be subject to controls by the manufacturer before acceptance. Check of incoming materials shall include control of inspection documents presented by the manufacturer of the raw materials.

The frequencies of controls conducted during manufacturing and on the finalised product are defined by taking account of the manufacturing process of the product and are laid down in the control plan.

The results of factory production control are recorded and evaluated. The records include at least the following data:

- Designation of the product, basic materials and components
- Type of control or test
- Date of manufacture of the product and date of testing of the product or basic materials or components
- Results of controls and tests and, if appropriate, comparison with requirements
- Name and signature of person responsible for factory production control

The records shall be kept at least for ten years time after the construction product has been placed on the market. On request they shall be presented to Österreichisches Institut für Bautechnik.

5.1.2 Declaration of performance

The manufacturer is responsible for preparing the declaration of performance. When all the criteria of the assessment and verification of constancy of performance are met, the manufacturer shall issue a declaration of performance.

Issued in Vienna on 15.12.2017
by Österreichisches Institut für Bautechnik

The original document is signed by:

Rainer Mikulits
Managing Director

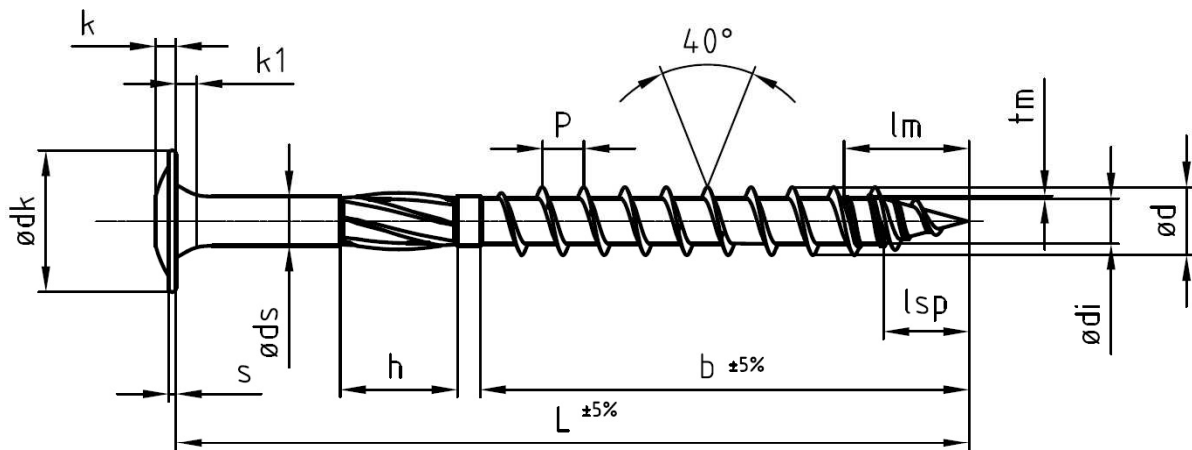

Dim	ødk	k	k1	s	øds	ød	ødi	P	ødR	ødn	lsp	h	tm
6.0 x)	14.0 ±0.80	3.0 ±1.0	1.4 ±0.8	1.5 ±0.8	4.3 ±0.21	6.0 ±0.30	3.95 ±0.20	3.4 ±0.34	5.0 ±0.5	4.7 ±0.53	7.3 ±1.9	10.2 ±1.0	0.30 ±0.07
8.0	20.0 ±1.50	3.5 ±1.0	1.9 ±1.0	2.0 ±0.9	5.9 ±0.29	8.0 ±0.40	5.30 ±0.26	5.6 ±0.56	6.8 ±0.6	7.1 ±0.73	8.2 ±2.1	10.2 ±1.0	0.60 ±0.12
10.0	25.0 ±2.00	4.5 ±1.2	2.6 ±1.5	2.0 ±0.9	7.1 ±0.35	10.0 ±0.50	6.20 ±0.31	6.6 ±0.66	8.3 ±0.8	8.4 ±0.87	10.1 ±2.3	10.2 ±1.0	0.60 ±0.12

x) Dim 6 optional with pitch $P = 4.6 \pm 0.46$

$l_m = l_{sp} + 1.0 P$

Detail: optional with cutting groove

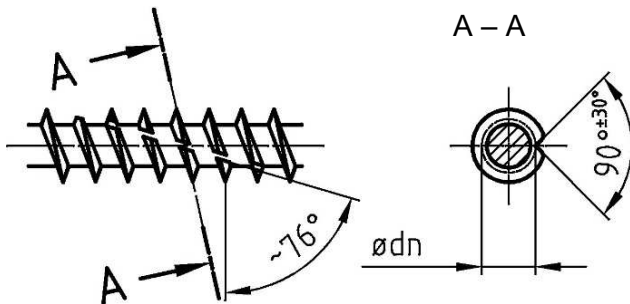

Detail: friction part

alternative without friction part

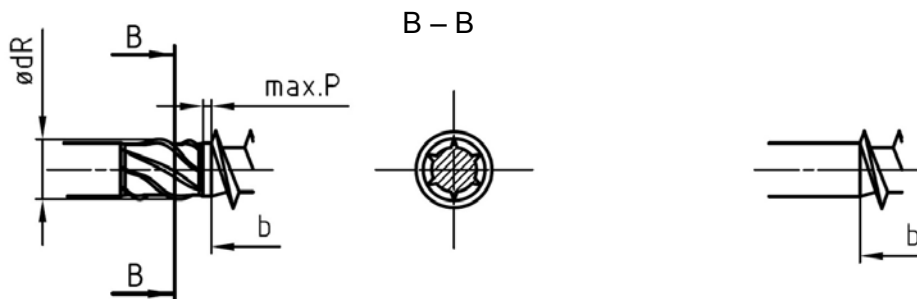

Simpson Strong-Tie® screws



ESCR/ESCR-S

Annex 1

of European Technical Assessment
 ETA-13/0796 of 15.12.2017

Alternative point types

Regular point

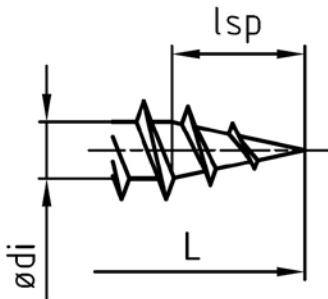

Half cut

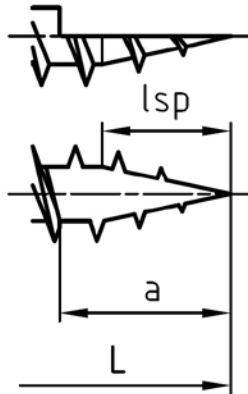

Scraping

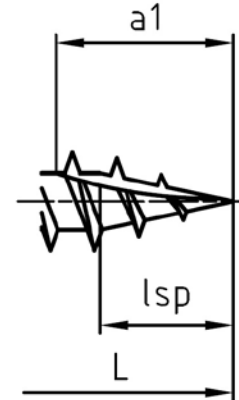

Dim	a	a1
6.0	8.5 ±2.0	12.5 ±2.0
8.0	11.0 ±2.0	16.5 ±2.0
10.0	13.0 ±2.0	19.5 ±2.0

length L and threaded part of the screw b					
Dim. 6.0		Dim. 8.0		Dim. 10.0	
L	b	L	b	L	b
60	36	80	54	80	60
70	36	100	54	100	60
80	48	120	54	120	60
90	48	140	84	140	60
100	48	160	84	160-500	100
110-300	64	180-500	100		

threaded part of the screw $b = b_{min}$
 b_{max} (fully threaded screw) = $L - k1$

Simpson Strong-Tie® screws



ESCR/ESCR-S

Annex 1

of European Technical Assessment
 ETA-13/0796 of 15.12.2017

UKR ... cutter ribs

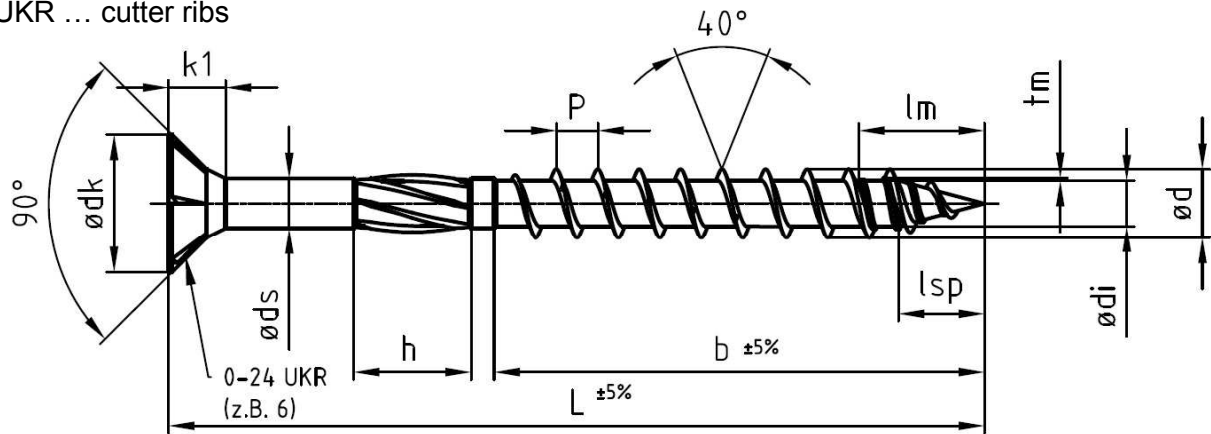

Dim	Ødk	kl	Øds	P	Ød	Ødi	lsp	Ødn	ØdR	h	tm	a	a1
4.0	8.0 ±0.70	3.0 ±0.30	2.8 ±0.14	2.2 ±0.22	4.0 ±0.20	2.55 ±0.13	4.6 ±1.5	3.1 ±0.32	3.2 ±0.3	6.2 ±1.0	0.20 ±0.05	5.4 ±2.0	8.5 ±2.0
4.5	9.0 ±0.70	3.5 ±0.35	3.2 ±0.16	2.4 ±0.24	4.5 ±0.22	2.75 ±0.14	5.0 ±1.6	3.5 ±0.35	3.6 ±0.3	8.2 ±1.0	0.30 ±0.05	6.0 ±2.0	9.0 ±2.0
5.0 x)	10.0 ±0.80	4.5 ±0.45	3.5 ±0.17	2.7 ±0.27	5.0 ±0.25	3.25 ±0.17	6.0 ±1.7	3.9 ±0.39	4.1 ±0.4	8.2 ±1.0	0.35 ±0.07	7.0 ±2.0	10.5 ±2.0
6.0 xx)	12.0 ±0.90	5.5 ±0.55	4.3 ±0.21	3.4 ±0.34	6.0 ±0.30	3.95 ±0.20	7.3 ±1.9	4.7 ±0.53	5.0 ±0.5	10.2 ±1.0	0.30 ±0.07	8.5 ±2.0	12.5 ±2.0
8.0	15.0 ±1.20	7.0 ±0.70	5.9 ±0.29	5.6 ±0.56	8.0 ±0.40	5.30 ±0.26	8.2 ±2.1	7.1 ±0.73	6.8 ±0.6	10.2 ±1.0	0.60 ±0.12	11.0 ±2.0	16.5 ±2.0
10.0	18.5 ±1.50	9.0 ±0.90	7.1 ±0.35	6.6 ±0.66	10.0 ±0.50	6.20 ±0.31	10.1 ±2.3	8.4 ±0.87	8.3 ±0.8	10.2 ±1.0	0.60 ±0.12	13.0 ±2.0	19.5 ±2.0

x) Dim 5 optional with pitch $P = 3.4 \pm 0.34$
 x) Dim 6 optional with pitch $P = 4.6 \pm 0.46$

$l_m = l_{sp} + 1.0 P$

Detail: optional with cutting groove

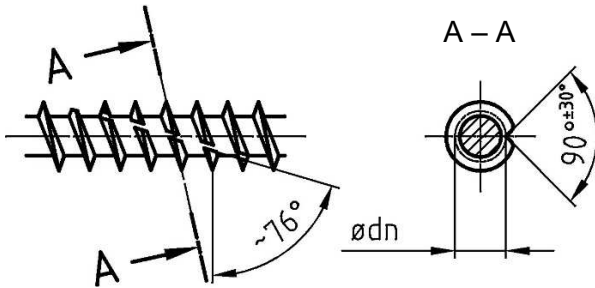

Detail: friction part

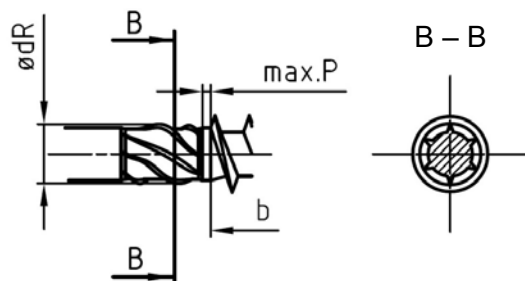

alternative without friction part

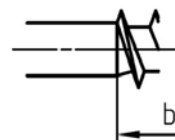

Simpson Strong-Tie® screws



ESCRC/ESCR-C-S

Annex 2

of European Technical Assessment
 ETA-13/0796 of 15.12.2017

Alternative point types

Regular point

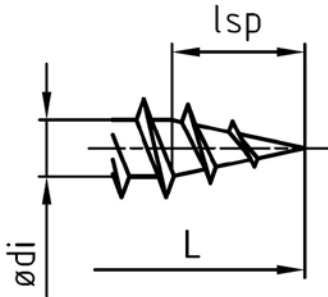

Half cut

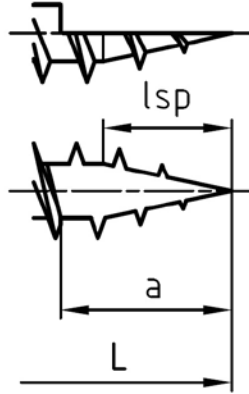

Scraping

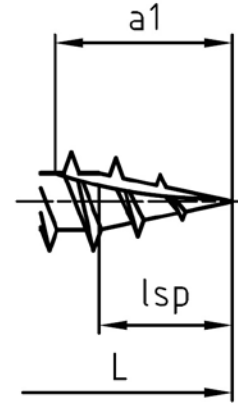

length L and threaded part of the screw b

Dim. 4.0		Dim. 4.5		Dim. 5.0		Dim. 6.0		Dim. 8.0		Dim. 10.0	
L	b	L	b	L	b	L	b	L	b	L	b
30	24	40	24	40	30	60	36	80	54	80	60
35	24	45	24	50	30	70	36	100	54	100	60
40	30	50	29	60	30	80	48	120	54	120	60
50	30	60	29	70	37	90	48	140	84	140	60
60	35	70	39	80	37	100	48	160	84	160-500	100
70	35	80	39	90-120	55	110-300	64	180-500	100		
80	35										

threaded part of the screw $b = b_{min}$
 b_{max} (fully threaded screw) = $L - k1$

Simpson Strong-Tie® screws



ESCRC/ESCRC-S

Annex 2

of European Technical Assessment
 ETA-13/0796 of 15.12.2017

UKR ... cutter ribs

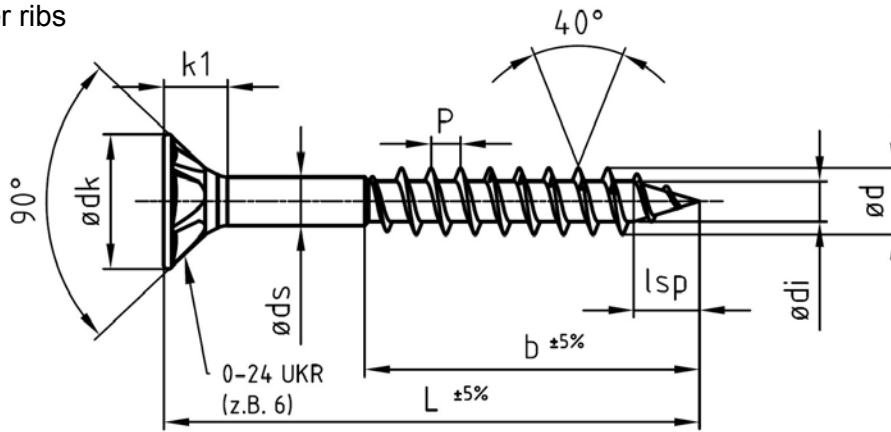

Dim	$\varnothing dk$	$k1$	$\varnothing ds$	P	$\varnothing d$	$\varnothing di$	lsp	$\varnothing dn$
4.0	8.0 ± 0.70	3.0 ± 0.30	2.8 ± 0.14	1.8 ± 0.18	4.0 ± 0.20	2.45 ± 0.13	5.6 ± 1.5	3.1 ± 0.32
4.5	9.0 ± 0.70	3.5 ± 0.35	3.2 ± 0.16	2.0 ± 0.20	4.5 ± 0.22	2.70 ± 0.14	5.0 ± 1.6	3.5 ± 0.35

Detail: optional with cutting groove

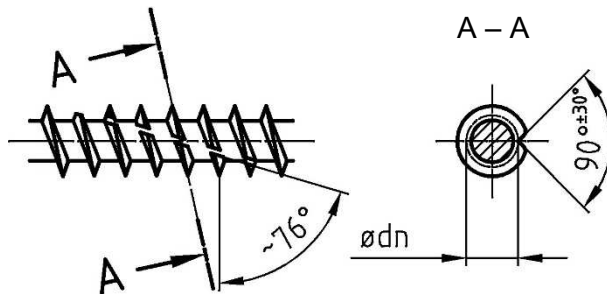

length L and threaded part of the screw b			
Dim. 4.0		Dim. 4.5	
L	b	L	b
25	20	25	19
30	17	30	19

threaded part of the screw $b = b_{min}$
 b_{max} (fully threaded screw) = $L - k1$

Simpson Strong-Tie® screws



ESCRS

Annex 3

of European Technical Assessment
 ETA-13/0796 of 15.12.2017

UKR ... cutter ribs

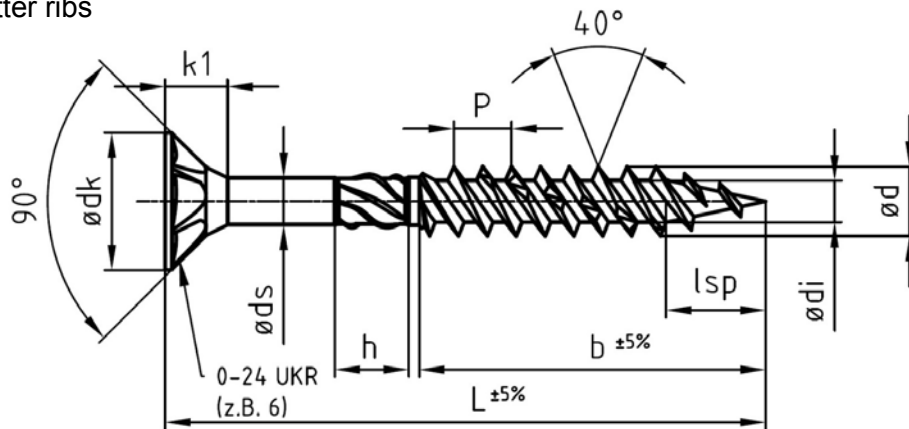

Dim	$\varnothing dk$	$k1$	$\varnothing ds$	P	ad	$\varnothing di$	lsp	$\varnothing dn$	$\varnothing dR$	h
4.0	8.0 ±0.70	3.0 ±0.30	2.8 ±0.14	3.4 ±0.34	4.0 ±0.20	2.40 ±0.12	4.6 ±1.5	3.1 ±0.32	3.2 ±0.3	6.2 ±1.0
4.5	9.0 ±0.70	3.5 ±0.35	3.2 ±0.16	3.8 ±0.38	4.5 ±0.22	2.70 ±0.14	5.0 ±1.6	3.5 ±0.35	3.6 ±0.3	8.2 ±1.0
5.0	10.0 ±0.80	4.5 ±0.45	3.5 ±0.17	4.2 ±0.42	5.0 ±0.25	3.10 ±0.16	6.0 ±1.7	3.9 ±0.39	4.1 ±0.4	8.2 ±1.0
6.0	12.0 ±0.90	5.5 ±0.55	4.3 ±0.21	5.0 ±0.50	6.0 ±0.30	3.80 ±0.19	7.3 ±1.9	4.7 ±0.53	5.0 ±0.5	10.2 ±1.0

Detail: cutting groove (alternative without cutting groove)

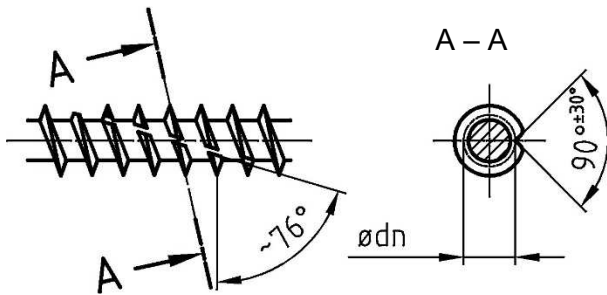

Detail: friction part

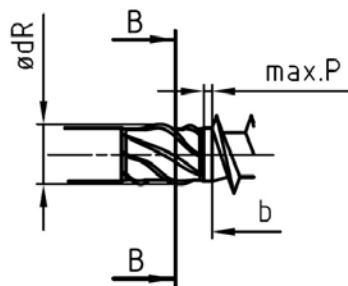

alternative without friction part

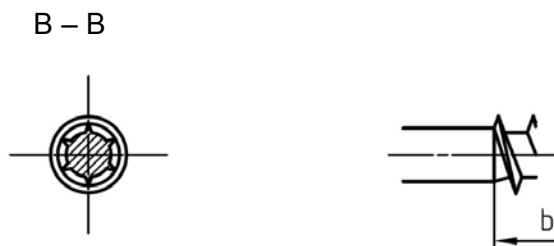

Simpson Strong-Tie® screws



ESCRS

Annex 3

of European Technical Assessment
 ETA-13/0796 of 15.12.2017

UKR ... cutter ribs

Countersunk head „FTC“

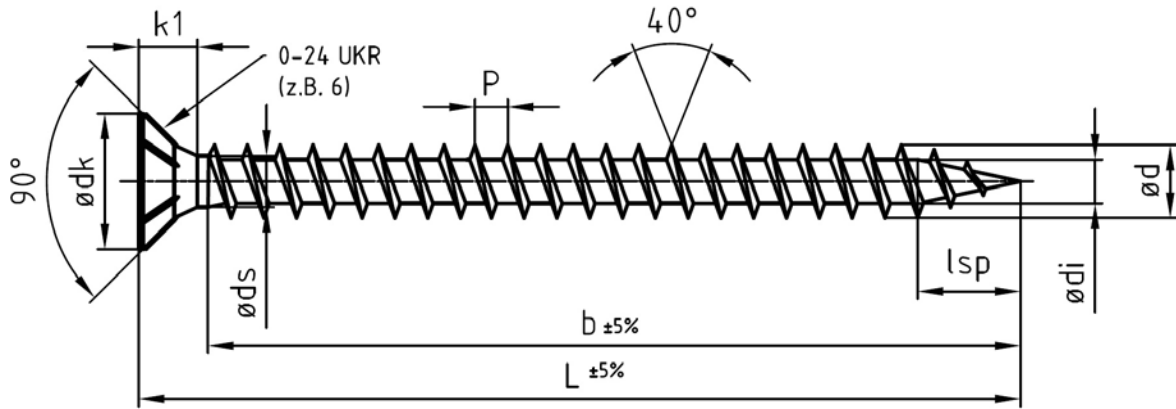

Cylinder head „FT/FTZ“

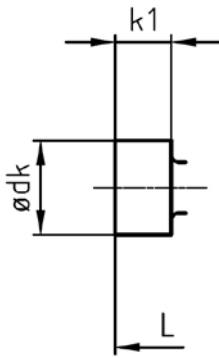

Kombi hexagonal head with thick shaft „SSTA“

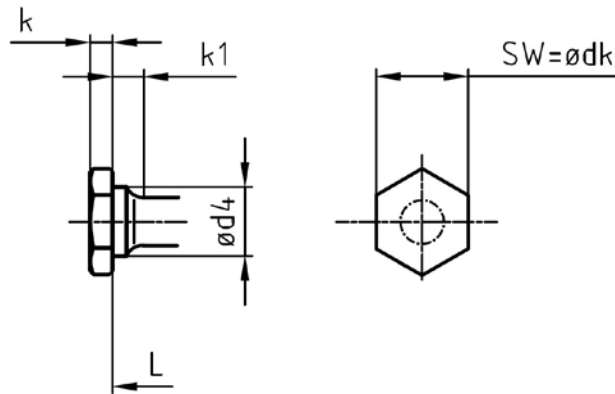

Alternative point types

Half cut

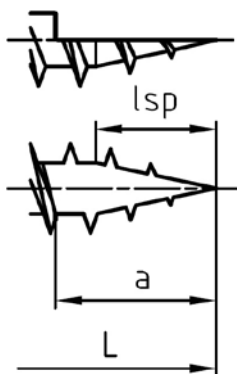

Scraping

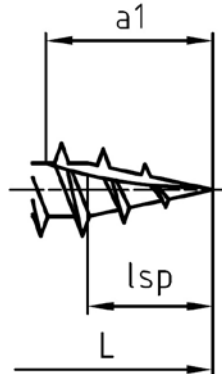

Simpson Strong-Tie® screws



ESCRFT/ESCRFT-S, ESCRFTZ/ESCRFTZ-S,
 ESCRFTC/ESCRFTC-S and SSTA

Annex 4

of European Technical Assessment
 ETA-13/0796 of 15.12.2017

Dim	countersunk head		cylinder head		kombi hexagonal head			
	Ødk	k1	Ødk	k1	SW=Ødk	k	k1	Ød4
6,0	12,0 ±0.90	5,5 ±0.55	8,15 ±0.40	4,7 ±0.8	9,0 -0.45	3,0 ±1.3	4,7 ±1.0	6,0 ±0.60
8,0	15,0 ±1.20	7,0 ±0.70	10,2 ±0.51	7,5 ±1.0	12,0 -0.60	4,5 ±1.3	6,3 ±1.0	8,0 ±0.80
10,0	18,5 ±1.50	9,0 ±0.90	13,4 ±0.67	8,0 ±1.0	15,0 -0.75	5,0 ±1.3	8,0 ±1.5	10,0 ±1.00
12,0	21,0 ±1.50	9,0 ±0.90	14,2 ±0.71	10,0 ±1.5	17,0 -0.85	5,5 ±1.3	10,0 ±2.0	12,0 ±1.20

Dim	Øds	Ød	Ødi	P	lsp	Ødn	ØdV	a	a1
6.0	4.3 ±0.21	6.0 ±0.30	3.80 ±0.19	2.6 ±0.26	7.3 ±1.9	4.7 ±0.53	4.4 ±0.43	8.5 ±2.0	12.5 ±2.0
8.0	5.9 ±0.29	8.0 ±0.40	5.20 ±0.26	3.8 ±0.38	8.2 ±2.1	7.1 ±0.73	6.0 ±0.59	11.0 ±2.0	16.5 ±2.0
10.0	7.1 ±0.35	10.0 ±0.50	6.10 ±0.31	4.5 ±0.45	10.1 ±2.3	8.4 ±0.87	7.1 ±0.72	13.0 ±2.0	19.5 ±2.0
12.0	8.2 ±0.41	12.0 ±0.60	6.80 ±0.34	6.2 ±0.62	11.2 ±2.6	8.9 ±0.89	7.9 ±0.80	15.0 ±2.0	22.5 ±2.0

length L and threaded part of the screw b							
Dim. 6.0		Dim. 8.0		Dim. 10.0		Dim. 12.0	
L	b	L	b	L	b	L	b
30-400	L-8	50-400	L-10	50-400	L-12	60-400	L-20
		401-1000	L-23	401-1000	L-24	401-1000	L-25

threaded part of the screw b:
 $b_{max} = L - k1$

Detail: optional with cutting groove

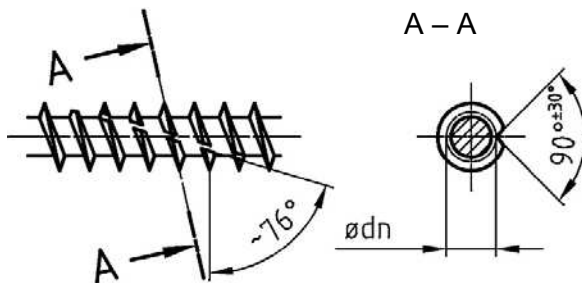

Detail: optional with compressor

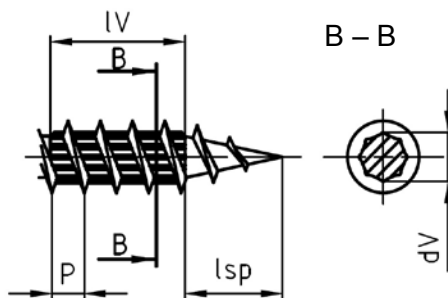

Dim	ØdV
6.0	4.4 ±0.43
8.0	6.0 ±0.59
10.0	7.1 ±0.72
12.0	7.9 ±0.80

Number of flanks: 4 – 8 IV = 2P to 4P (1P for L ≤ 100)

Simpson Strong-Tie® screws



ESCRFT/ESCRFT-S, ESCRFTZ/ESCRFTZ-S,
 ESCRFTC/ESCRFTC-S and SSTA

Annex 4

of European Technical Assessment
 ETA-13/0796 of 15.12.2017

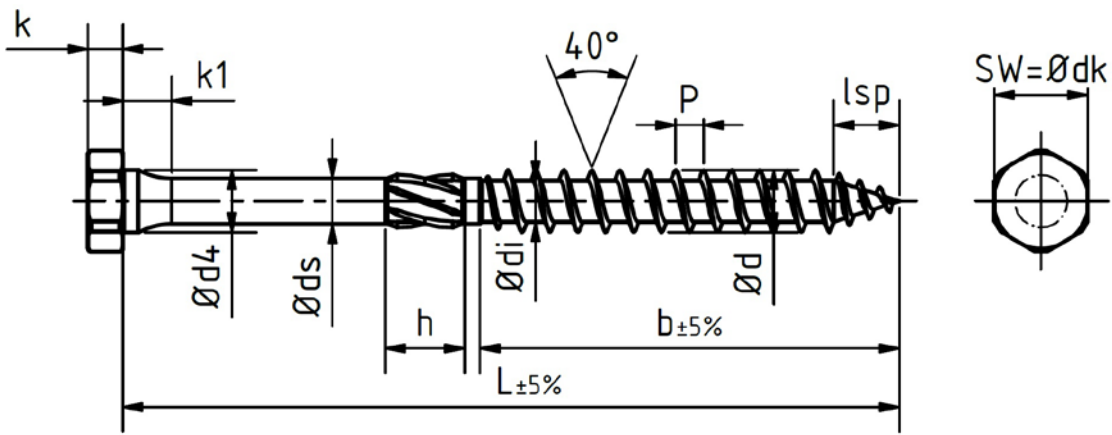

Dim	SW=Ødk	k	k1	Ød4	Øds	Ød	Ødi	P	lsp	Ødn	ØdR	h
8.0	12.0 -0.60	4.5 ±1.3	6.3 ±1.0	8.0 ±0.80	5.9 ±0.29	8.0 ±0.40	5.20 ±0.26	3.8 ±0.38	8.2 ±2.1	7.1 ±0.73	6.8 ±0.6	10.2 ±1.0
10.0	15.0 -0.75	5.0 ±1.3	8.0 ±1.5	10.0 ±1.00	7.1 ±0.35	10.0 ±0.50	6.10 ±0.31	4.5 ±0.45	10.1 ±2.3	8.4 ±0.87	8.3 ±0.8	10.2 ±1.0
12.0	17.0 -0.85	5.5 ±1.3	10.0 ±2.0	12.0 ±1.20	8.2 ±0.41	12.0 ±0.60	6.80 ±0.34	6.2 ±0.62	11.2 ±2.6	8.9 ±0.89	9.7 ±1.0	14.2 ±1.0

Detail: optional with cutting groove

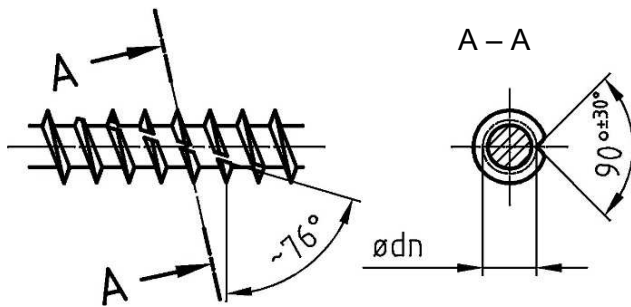

Detail: friction part

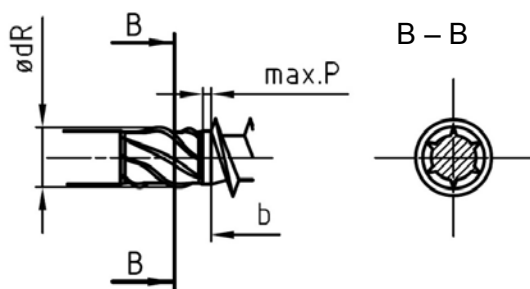

alternative without friction part

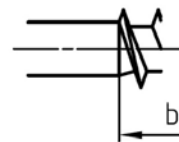

Simpson Strong-Tie® screws



ESCRHD/HRD

Annex 5

of European Technical Assessment
 ETA-13/0796 of 15.12.2017

Detail: optional with compressor

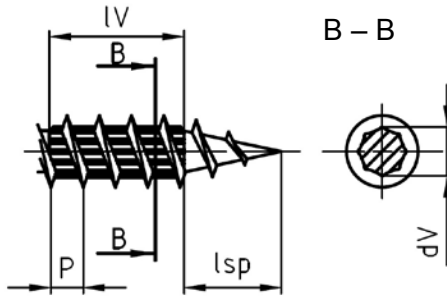

Dim	∅dV
6.0	4.4 ±0.43
8.0	6.0 ±0.59
10.0	7.1 ±0.72
12.0	7.9 ±0.80

Number of flanks: 4 – 8 IV = 2P to 4P (1P for L ≤ 100)

Alternative point types

Half cut

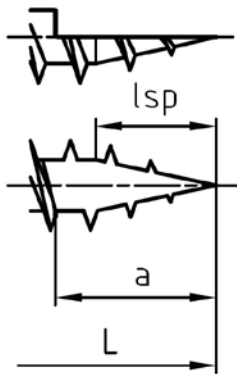

Scraping

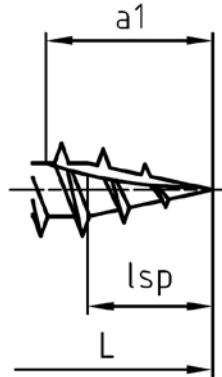

Dim	a	a1
6.0	8.5 ±2.0	12.5 ±2.0
8.0	11.0 ±2.0	16.5 ±2.0
10.0	13.0 ±2.0	19.5 ±2.0

length L and threaded part of the screw b					
Dim. 8.0		Dim. 10.0		Dim. 12.0	
L	b	L	b	L	b
40	28	60	45	60	48
50	35	70	49	70-80	58
60	45	80-90	54	90-100	70
70	49	100	65	110	84
80	54	110-130	84	120-130	84
90-100	65	140-180	108	140-160	100
110-140	84	190-500	125	170-220	125
150-500	100			230-500	144

Simpson Strong-Tie® screws



ESCRHD/HRD

Annex 5

of European Technical Assessment
 ETA-13/0796 of 15.12.2017

Cylinder head

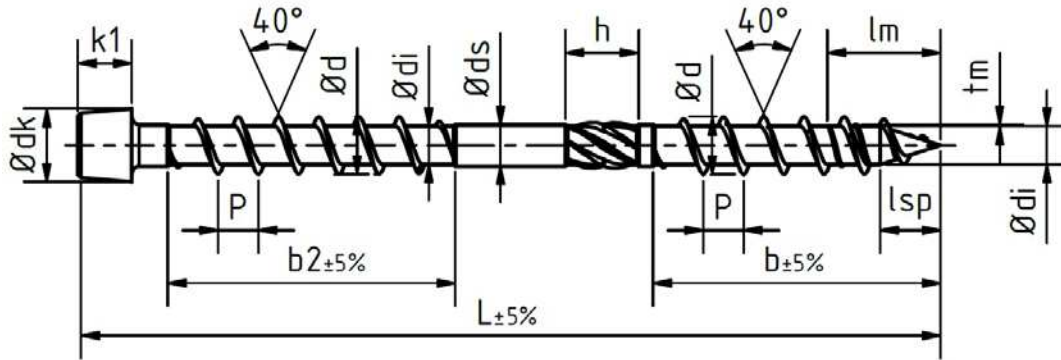

Countersunk head with cutter ribs (UKR)
 UKR ... cutter ribs

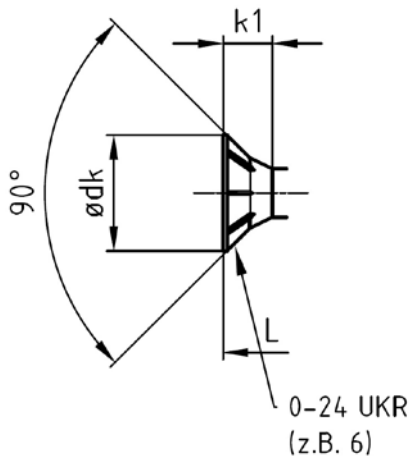

Dim	countersunk head		cylinder head	
	Ødk	k1	Ødk	k1
8,0	15,0 ±1.20	7,0 ±0.70	10,2 ±0.51	7,5 ±1.0

Dim	Øds	Ød	Ødi	P	lsp	Ødn	ØdR	h	tm	a	a1
8.0	5.9 ±0.29	8.0 ±0.40	5.30 ±0.26	5.6 ±0.56	8.2 ±2.1	7.1 ±0.73	6.8 ±0.6	10.2 ±1.0	0.60 ±0.12	11.0 ±2.0	16.5 ±2.0

Simpson Strong-Tie® screws



ESCRT2R/ESCRT2R-S

Annex 6

of European Technical Assessment
 ETA-13/0796 of 15.12.2017

Detail: cutting groove (alternative without cutting groove)

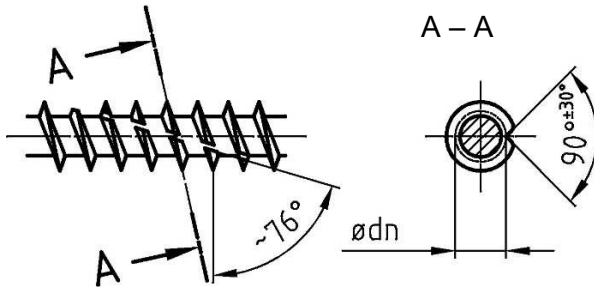

Detail: friction part

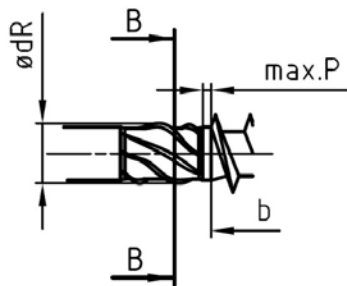

alternative without friction part

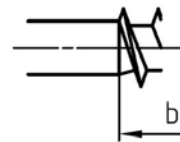
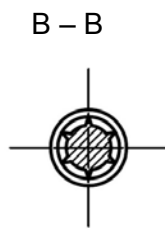

length L and threaded part of the screw b Dim. 8.0		
L	b	b2
120-180	40	40
180-200	54	40
220-240	80	80
260-600	100	80

threaded part of the screw $b / b2 = b_{min}$

Simpson Strong-Tie® screws



Annex 6

of European Technical Assessment
 ETA-13/0796 of 15.12.2017

ESCRT2R/ESCRT2R-S

electronic copy

UKR ... cutter ribs

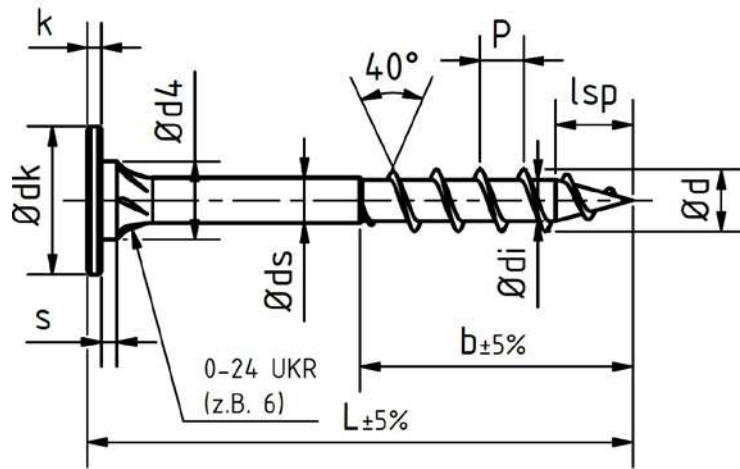

Dim	Ødk	k	s	Ød4	Øds	Ød	Ødi	P	Ødn	lsp
6,0	13,0 ±0.65	2,0 ±0.2	1,25 ±1.0	8,0 ±0.4	4,3 ±0.21	6,0 ±0.30	3,95 ±0.20	3,4 ±0.34	5,3 ±0.53	7,3 ±1.9
8,0	19,0 ±1.50	2,4 ±0.3	2,00 ±1.0	10,0 ±0.5	5,9 ±0.29	8,0 ±0.40	5,30 ±0.26	5,6 ±0.56	7,3 ±0.73	8,2 ±2.1
10,0	24,0 ±2.5	3,0 ±0.3	3,00 ±1.0	13,0 ±0.65	7,1 ±0.35	10,0 ±0.50	6,20 ±0.31	6,6 ±0.66	8,7 ±0.87	10,1 ±2.3
12,0	24 ±2.5 (26)	3,0 ±0.3	3,00 ±1.0	13,0 ±0.65	8,2 ±0.41	12,0 ±0.60	6,80 ±0.34	6,2 ±0.62	9,1 ±0.87	11,2 ±2.6

Detail: optional with cutting groove

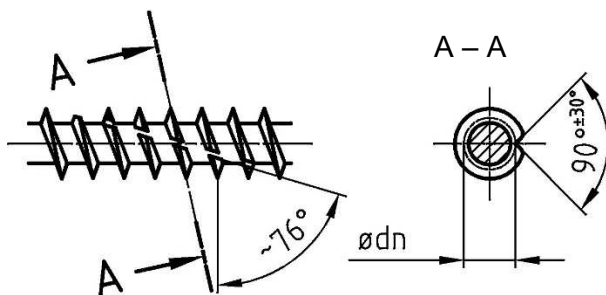

length L and threaded part of the screw b							
Dim. 6.0		Dim. 8.0		Dim. 10.0		Dim. 12.0	
L	b	L	b	L	b	L	b
20	10	30-40	20	50-90	30	50-90	30
30-40	20	50-70	35				
50-70	37						

threaded part of the screw $b = b_{min}$

Simpson Strong-Tie® screws



ESCRH/ESCRH-S

Annex 7

of European Technical Assessment
 ETA-13/0796 of 15.12.2017

UKR ... cutter ribs

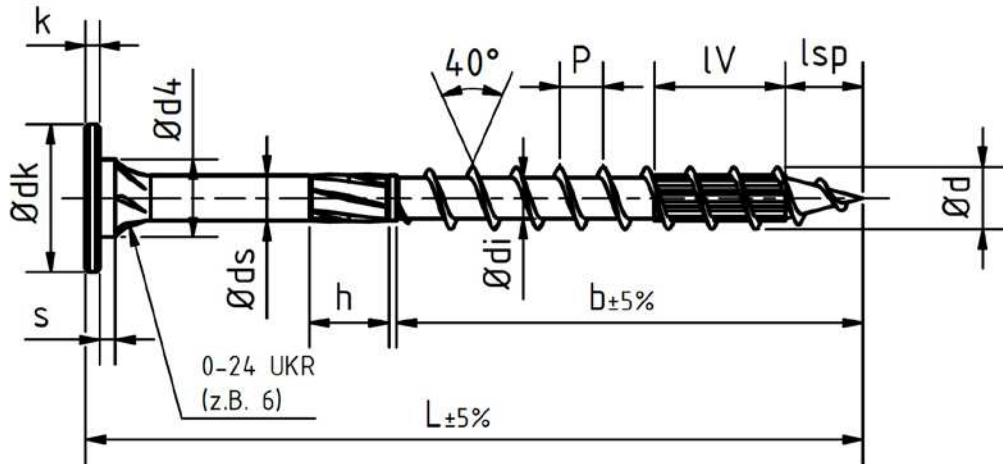

Dim	Ødk	k	s	Ød4	Øds	Ød	Ødi	P	Ødn	lsp
6,0	13,0 ±0.65	2,0 ±0.2	1,25 ±1.0	8,0 ±0.4	4,3 ±0.21	6,0 ±0.30	3,95 ±0.20	3,4 ±0.34	5,3 ±0.53	7,3 ±1.9
8,0	19,0 ±1.50	2,4 ±0.3	2,00 ±1.0	10,0 ±0.5	5,9 ±0.29	8,0 ±0.40	5,30 ±0.26	5,6 ±0.56	7,3 ±0.73	8,2 ±2.1
10,0	24,0 ±2.5	3,0 ±0.3	3,00 ±1.0	13,0 ±0.65	7,1 ±0.35	10,0 ±0.50	6,20 ±0.31	6,6 ±0.66	8,7 ±0.87	10,1 ±2.3
12,0	24 ±2.5 (26)	3,0 ±0.3	3,00 ±1.0	13,0 ±0.65	8,2 ±0.41	12,0 ±0.60	6,80 ±0.34	6,2 ±0.62	9,1 ±0.87	11,2 ±2.6

Detail: optional with cutting groove

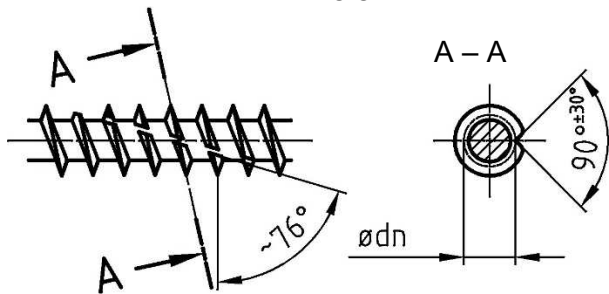

Detail: friction part

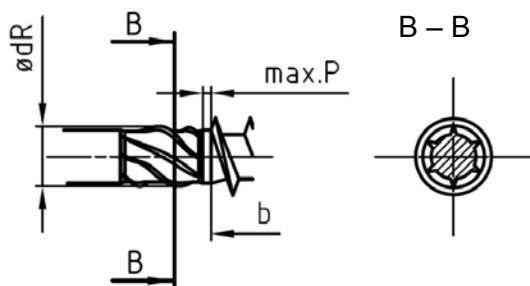

alternative without friction part

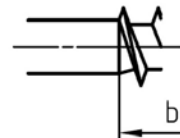

Simpson Strong-Tie® screws



Annex 7

of European Technical Assessment
 ETA-13/0796 of 15.12.2017

ESCRH/ESCRH-S

Detail: compressor

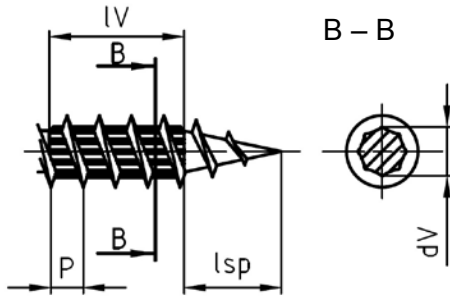

Dim	∅dV
6.0	4.4 ±0.43
8.0	6.0 ±0.59
10.0	7.1 ±0.72
12.0	7.9 ±0.80

Number of flanks: 4 – 8 IV = 2P to 4P (1P for L ≤ 100)

length L and threaded part of the screw b							
Dim. 6.0		Dim. 8.0		Dim. 10.0		Dim. 12.0	
L	b	L	b	L	b	L	b
80-100	48	80-120	54	100-120	60	100	60
120	70					120	80

threaded part of the screw b = b_{min}

Simpson Strong-Tie® screws



ESCRH/ESCRH-S

Annex 7

of European Technical Assessment
 ETA-13/0796 of 15.12.2017

electronic copy

Washer (for screws with 90° head, only)

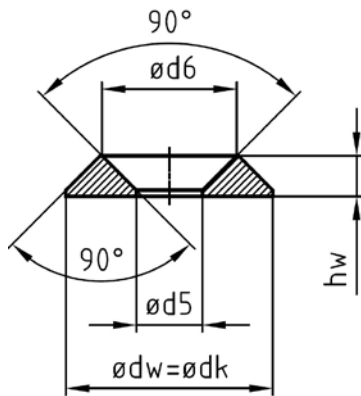

Dim	$\varnothing dw = \varnothing dk$	$\varnothing d6$	$\varnothing d5$	hw
6.0	22.0 ±2.0	14.5 ±1.5	8.5 ±1.0	4.5 ±1.0
8.0	28.0 ±2.0	19.0 ±1.9	10.0 ±2.0	6.0 ±1.0
10.0	35.0 ±3.0	22.5 ±2.2	12.0 ±2.0	7.0 ±1.0
12.0	42.0 ±3.0	25.0 ±2.5	14.0 ±2.0	7.5 ±1.0

KS-Drive

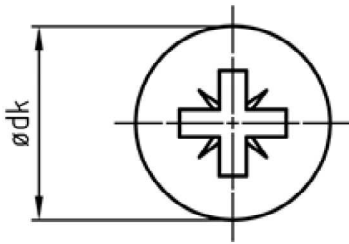

T-Drive

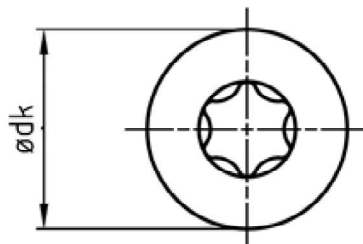

Dim	KS	T
4.0	KS 2	T10 / T15 / T20
4.5	KS 2	T15 / T20 / T25
5.0	KS 2	T20 / T25 / T30
6.0	KS 3	T20 / T25 / T30
7.0	KS 3	T25 / T30
8.0	KS 4	T30 / T40
10.0	KS 4	T40 / T50
12.0	KS 4	T40 / T50 / T55

head labelling optional

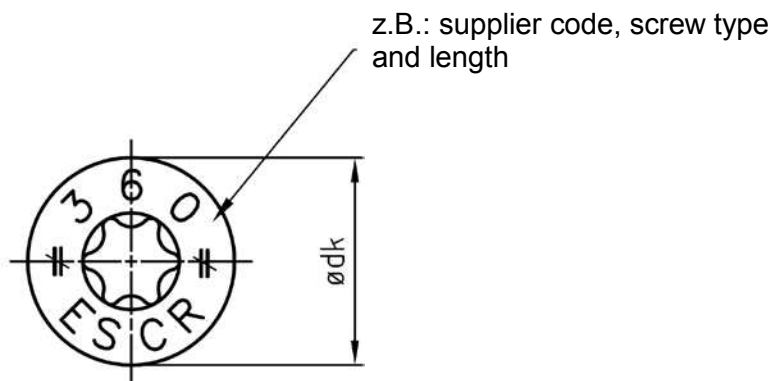

Simpson Strong-Tie® screws



Annex 8

of European Technical Assessment
 ETA-13/0796 of 15.12.2017

Drive types and head labeling

Table A9.1: Characteristic head pull-through capacities of Simpson Strong-Tie® screws ESCRC/ESCRC-S, ESCRS and ESCRFTC/ESCRFTC-S in solid softwood or glued laminated timber for 90° heads; head diameter 8 to 21 mm

ESCRC/ESCRC-S, ESCRS, and ESCRFTC/ESCRFTC-S			Head diameter (90° heads) ¹⁾							
Product characteristic			8	9	10	12	14	15	18.5	21
Characteristic head pull-through parameter ($\rho_k = 350 \text{ kg/m}^3$)	$f_{\text{head,k}}$	N/mm ²	17.1	17.6	14.6	14.6	13.1	12.4	12.2	10.3

¹⁾ Linear interpolation is possible for head diameters in between the stated values

Table A9.2: Characteristic head pull-through capacities of Simpson Strong-Tie® screws ESCR/ESCR-S, ESCRHD/HRD, ESCRH/ESCRH-S, SSTA and washers in solid softwood or glued laminated timber for 180° heads; washer diameter 14 to 42 mm

ESCR/ESCR-S, ESCRHD/HRD, ESCRH/ESCRH-S, SSTA and washers			Head diameter (180° heads) ¹⁾						
Product characteristic			14	20	22	25	27	33	42
Characteristic head pull-through parameter ($\rho_k = 350 \text{ kg/m}^3$)	$f_{\text{head,k}}$	N/mm ²	16.7	17.6	20.4	15.2	14.5	10.0	6.5
	$f_{\text{head,k}}$ ESCRH ESCRH-S		16.7	23.5	20.4	15.2	14.5	10.0	6.5

¹⁾ Linear interpolation is possible for head diameters in between the stated values

Simpson Strong-Tie® screws



Characteristic data of the screws

Annex 9

of European Technical Assessment
 ETA-13/0796 of 15.12.2017

Table A9.3: Characteristic load bearing capacities of Simpson Strong-Tie® screws SSTA and ESCRHD/HRD according to Annex 4 and Annex 5; screw diameter 4 to 6 mm

SSTA (Annex 4) and ESCRHD/HRD (Annex 5)			Screw diameter			
Product characteristic			4	4.5	5	6
Max. length	l_{max}	mm	70	80	120	300
Characteristic tensile strength	$f_{tens,k}$	kN	5.0	5.8	8.5	12.4
Characteristic yield moment	$M_{y,k}$	Nm	3.2	4.9	6.5	10.1
Characteristic withdrawal parameter angle screw-axis to grain: 90° ($\rho_k = 350 \text{ kg/m}^3$)	$f_{ax,k,90^\circ}$	N/mm ²	14.8	13.8	12.8	12.1
Characteristic yield strength	$f_{y,k}$	N/mm ²	900			
Characteristic torsional strength	$f_{tor,k}$	Nm	3.0	4.2	6.2	9.5
Insertion moment ($\rho_k = 450 \text{ kg/m}^3$)	$R_{tor,m}$	Nm	1.4	1.9	3.8	6.5

Table A9.4: Characteristic load bearing capacities of Simpson Strong-Tie® screws SSTA, ESCRHD/HRD and ESCRH Ø 12 mm according to Annex 4, Annex 5 and Annex 7; screw diameter 7 to 12 mm

SSTA (Annex 4), ESCRHD/HRD (Annex 5) and ESCRH Ø 12 mm (Annex 7)			Screw diameter			
Product characteristic			7	8	10	12
Max. length	l_{max}	mm	300	400	500	500
Characteristic tensile strength	$f_{tens,k}$	kN	17.1	22.0	32.0	42.0
Characteristic yield moment	$M_{y,k}$	Nm	12.6	22.6	33.0	58.6
Characteristic withdrawal parameter angle screw-axis to grain: 90° ($\rho_k = 350 \text{ kg/m}^3$)	$f_{ax,k,90^\circ}$	N/mm ²	11.5	10.9	9.8	8.9
Characteristic yield strength	$f_{y,k}$	N/mm ²	900			
Characteristic torsional strength	$f_{tor,k}$	Nm	16.1	24.8	44.8	59.6
Insertion moment ($\rho_k = 450 \text{ kg/m}^3$)	$R_{tor,m}$	Nm	8.1	16.5	28.0	27.0

Simpson Strong-Tie® screws



Characteristic data of the screws

Annex 9

of European Technical Assessment
ETA-13/0796 of 15.12.2017

**Table A9.5: Characteristic load bearing capacities of Simpson Strong-Tie® screws
 ESCR/ESCR-S, ESCRC/ESCRC-S, ESCRT2R/ESCRT2R-S and ESCRH/ESCRH-S according to
 Annex 1, Annex 2, Annex 6 and Annex 7**

ESCR/ESCR-S (Annex 1), ESCRC/ESCRC-S (Annex 2), ESCRT2R/ESCRT2R-S (Annex 6) and ESCRH/ESCRH-S (Annex 7)				Screw diameter					
Product characteristic				4	4.5	5	6	8	10
Max. length	carbon steel	l_{max}	mm	70	80	120	300	500	500
	stainless steel			-	-	-	-	240	-
Characteristic tensile strength	carbon steel	$f_{tens,k}$	kN	5.0	5.8	8.8	12.8	22.7	33.2
	stainless steel			-	-	-	-	16.0	-
Characteristic yield moment	carbon steel	$M_{y,k}$	Nm	3.2	4.9	6.5	10.1	22.6	33.0
	stainless steel			-	-	-	-	16.6	-
Characteristic withdrawal parameter angle screw-axis to grain: 90° ($\rho_k = 350 \text{ kg/m}^3$)		$f_{ax,k,90^\circ}$	N/mm ²	14.8	13.8	13.6	13.0	10.7	9.5
Characteristic yield strength		$f_{y,k}$	N/mm ²	900 (carbon steel) 735 (stainless steel)					
Characteristic torsional strength	carbon steel	$f_{tor,k}$	Nm	3.0	4.2	6.3	10.1	25.6	47.5
	stainless steel			-	-	-	-	18.8	-
Insertion moment	carbon steel $\rho_k = 450 \text{ kg/m}^3$	$R_{tor,m}$	Nm	1.2	1.6	2.1	2.5	8.3	14.2
	stainless steel $\rho_k = 480 \text{ kg/m}^3$			-	-	-	-	8.0	-

Simpson Strong-Tie® screws



Annex 9

of European Technical Assessment
 ETA-13/0796 of 15.12.2017

Characteristic data of the screws

Table A9.7: Characteristic load bearing capacities of Simpson Strong-Tie® screws ESCRFTC and ESCRFT/FTZ without compressor and cutting groove according to Annex 4

ESCRFTC and ESCRFT/FTZ without compressor and cutting groove (Annex 4)			Screw diameter		
Product characteristic			6	8	10
Max. length	l_{max}	mm	220	400	400
Characteristic tensile strength	$f_{tens.k}$	kN	12.5	23.5	33.0
Characteristic yield moment	$M_{y.k}$	Nm	10.0	24.0	35.8
Characteristic withdrawal parameter angle screw-axis to grain: 90° ($\rho_k = 350 \text{ kg/m}^3$)	$f_{ax.k.90^\circ}$	N/mm ²	13.5	10.9	11.5
Characteristic yield strength	$f_{y.k}$	N/mm ²	950		
Characteristic torsional strength	$f_{tor.k}$	Nm	10.4	26.5	47.0
Insertion moment ($\rho_k = 450 \text{ kg/m}^3$)	$R_{tor.m}$	Nm	6.9	15.6	23.0
Insertion moment ($\rho_k = 450 \text{ kg/m}^3$) for half cut	$R_{tor.m. HT}$	Nm	-	13.0	17.6
Slip modulus	K_{ser}	N/mm	see A.9.4		

Simpson Strong-Tie® screws



Characteristic data of the screws

Annex 9

of European Technical Assessment
 ETA-13/0796 of 15.12.2017

Table A9.8: Characteristic load bearing capacities of Simpson Strong-Tie® screws ESCRFTC/ESCRFTC-S, ESCRFT/ESCRFT-S, ESCRFTZ/ESCRFTZ-S and ESCRH Ø 12 mm with compressor and cutting groove according to Annex 4 and Annex 7

ESCRFTC/ESCRFTC-S, ESCRFT/ESCRFT-S, ESCRFTZ/ESCRFTZ-S (Annex 4) and ESCRH Ø 12 mm (Annex 7) with compressor and cutting groove				Screw diameter		
Product characteristic				8	10	12
Max. length	carbon steel	l_{max}	mm	1000	1000	1000
	stainless steel			300	-	-
Characteristic tensile strength	carbon steel	$f_{tens.k}$	kN	24.1	40.0	46.7
	stainless steel			13.8	-	-
Characteristic yield moment	carbon steel	$M_{y.k}$	Nm	20.3	36.7	48.5
	stainless steel			14.2	-	-
Characteristic withdrawal parameter angle screw-axis to grain: 90° ($\rho_k = 350 \text{ kg/m}^3$)		$f_{ax.k.90^\circ}$	N/mm ²	13.1	12.5	11.2
Characteristic yield strength		$f_{y.k}$	N/mm ²	950 (carbon steel) 657 (stainless steel)		
Characteristic torsional strength	carbon steel	$f_{tor.k}$	Nm	25.8	55.0	77.1
	stainless steel			17.5	-	-
Insertion moment for half cut	carbon steel $\rho_k = 450 \text{ kg/m}^3$	$R_{tor.m.HT}$	Nm	8.7	15.6	27.9
	stainless steel $\rho_k = 480 \text{ kg/m}^3$			7.9	-	-
Slip modulus		K_{ser}	N/mm	see A.9.4		

Simpson Strong-Tie® screws



Annex 9

of European Technical Assessment
ETA-13/0796 of 15.12.2017

Characteristic data of the screws

A.9.1 General

The characteristic load bearing capacities in Tables A9.1 to A9.8 are given for timber of strength class C24 according to EN 338 ($\rho_k = 350 \text{ kg/m}^3$). For timber with a deviating density the characteristic withdrawal parameter as well as the characteristic head pull-through parameter shall be corrected by the factor

$$k_{dens} = \left(\frac{\rho_k}{350} \right)^{0.8}$$

Where

ρ_k Characteristic density of timber in kg/m^3

The minimum penetration length of screws in the load-bearing wood-based members shall be $4 d$.

A bending angle of 45° must be reached for all screws.

A.9.2 Characteristic withdrawal parameter

For angles $0^\circ \leq \alpha \leq 45^\circ$ between screw-axis and direction of wood-fibre, $f_{ax,k,\alpha}$ is obtained by

$$f_{ax,k,\alpha} = k_{ax} \cdot f_{ax,k,90^\circ}$$

with

$$k_{ax} = 0,3 + \frac{0,7 \cdot \alpha}{45^\circ}$$

For angles $45^\circ \leq \alpha \leq 90^\circ$ between screw-axis and direction of wood-fibre, $f_{ax,k,\alpha}$ remains constant.

A.9.3 Characteristic head pull-through capacity for wood based panels

The characteristic value of the head pull-through parameter for a characteristic density of 380 kg/m^3 of the timber and for the following wood based panels

- Plywood according to EN 636 and EN 13986,
- Oriented strand boards, OSB, according to EN 300 and EN 13986,
- Solid wood panels according to EN 13353 and EN 13986,
- Particleboard according to EN 312 and EN 13986,
- Fibreboards according to EN 622-2, EN 622-3 and EN 13986,
- Cement-bonded particle boards according to EN 634-1 and EN 13986

with thicknesses of more than 20 mm is

$$f_{head,k} = 10 \text{ N/mm}^2$$

Simpson Strong-Tie® screws



Annex 9

of European Technical Assessment
 ETA-13/0796 of 15.12.2017

Characteristic data of the screws

electronic copy

For wood based panels with a thickness between 12 mm and 20 mm the characteristic value of the head pull-through parameter is

$$f_{head,k} = 8 \text{ N/mm}^2$$

For plywood with a minimum of 7 layers and a minimum thickness of 18 mm, the characteristic value of the head pull-through parameter for a characteristic density of 490 kg/m³ is ($d_k \geq 18.8 \text{ mm}$)

$$f_{head,k} = 16 \text{ N/mm}^2$$

For wood based panels with a thickness of less than 12 mm the characteristic head pull-through capacity shall be based on a characteristic value of the head pull-through parameter of 8 N/mm², and limited to 400 N complying with the minimum thicknesses of the wood based panels of 1.2 d, with d as outer thread diameter. In addition the minimum thicknesses of Table A9.10 apply.

Table A9.10 Minimum thicknesses of wood based panels

Wood based panel	Minimum thickness in mm
Plywood	6
Oriented strand board, OSB	8
Solid wood panels	12
Particleboard	8
Fibreboards	6
Cement-bonded particle boards	8

A.9.4 Slip modulus for mainly axially loaded screws

The axial slip modulus K_{ser} for the serviceability limit state used for connection of individual members in bending beams under flexible jointing shall be taken for screws independent of angle α to the grain as

$$K_{ser} = 25 \cdot d \cdot l_{ef} \dots \text{ in N/mm for softwood}$$

$$K_{ser} = 30 \cdot d \cdot l_{ef} \dots \text{ in N/mm for hardwood}$$

with

d = outer thread diameter of the screw in mm

l_{ef} = penetration length of the threaded part of the screw in the timber member in mm

Simpson Strong-Tie® screws



Annex 9

of European Technical Assessment
 ETA-13/0796 of 15.12.2017

Characteristic data of the screws

A.9.5 Compressive loading for fully threaded screws (unsupported buckling, e.g. soft insulating materials)

The design load carrying capacity for Simpson Strong-Tie® screws with a full thread for an angle $30^\circ \leq \alpha \leq 90^\circ$ between screw-axis and direction of wood-fibre for compressive loading is given as

$$F_{c,\alpha,Rd} = \min\{F_{ax,\alpha,d}; F_{ki,d}\} \quad \text{in N}$$

with

$$F_{ax,\alpha,d} = f_{ax,d,\alpha} \cdot d \cdot l_{ef}$$

$f_{ax,d,\alpha}$ = design value of the axial withdrawal capacity of the threaded part of the screw calculated from the characteristic values given in Table A9.3 to A9.8 in N/mm²

d = outer thread diameter of the screw in mm

l_{ef} = penetration length of the threaded part of the screw in the timber member in mm

$$F_{ki,d} = F_{ki,k} / \gamma_M = \frac{\chi \cdot N_{pl,k}}{\gamma_M}$$

$$\chi = 1 \text{ for } \bar{\lambda} \leq 0.2 \text{ or } \chi = \frac{1}{\phi + \sqrt{\phi^2 - \bar{\lambda}^2}} \text{ for } \bar{\lambda} > 0.2$$

$$\phi = 0.5 \cdot [1 + 0.49 \cdot (\bar{\lambda} - 0.2) + \bar{\lambda}^2]$$

$$\bar{\lambda} = \sqrt{\frac{N_{pl,k}}{N_{ki,k}}}$$

$$N_{pl,k} = \pi \cdot \frac{d_i^2}{4} f_{y,k} \quad \text{in N}$$

d_i = inner thread diameter for fully threaded screw, shank diameter d_s for screws with 2 threads

$f_{y,k}$ = characteristic yield strength of the screw according to Table A9.3 to A9.8

$N_{ki,k}$ = characteristic ideal elastic buckling load

$$N_{ki,k} = \sqrt{c_h \cdot E_s \cdot I_s} \quad \text{in N}$$

c_h = elastic foundation of the screw

Simpson Strong-Tie® screws



Annex 9

of European Technical Assessment
 ETA-13/0796 of 15.12.2017

Characteristic data of the screws

$$c_h = (0.19 + 0.012 \cdot d) \cdot \rho_k \cdot \left(\frac{90^\circ + \alpha}{180^\circ} \right) \text{ in N/mm}^2$$

ρ_k = characteristic density of the wood-based member in kg/m³

α = angle between screw axis and grain direction, $30^\circ \leq \alpha \leq 90^\circ$

$$E_s \cdot I_s = \frac{210000 \cdot \pi \cdot d_i^4}{64} = \text{bending stiffness in N/mm}^2$$

A.9.6 Compression reinforcement (screws in timber)

The compression force shall evenly be distributed to the screws used as compression reinforcement. The screws are driven into the timber member perpendicular to the contact surface under an angle between the screw axis and the grain direction of 45° to 90°. The screw heads must be flush with the timber surface.

Reinforcing screws for wood-based panels are not covered by this European Technical Assessment.

For the design of reinforced contact areas the following conditions shall be met independently of the angle between the screw axis and the grain direction.

The design resistance of a reinforced contact area is:

$$R_{90,d} = \min \left\{ \begin{array}{l} k_{c,90} \cdot B \cdot l_{ef,1} \cdot f_{c,90,d} + n \cdot \min \{ F_{ax,\alpha,d}; F_{ki,d} \} \\ B \cdot l_{ef,2} \cdot f_{c,90,d} \end{array} \right\}$$

where:

$k_{c,90}$ = parameter according to EN 1995-1-1, 6.1.5

B = bearing width in mm

$l_{ef,1}$ = effective contact length according to EN 1995-1-1, 6.1.5 in mm

$f_{c,90,d}$ = design compressive strength perpendicular to the grain (EN 338/EN 14081-1) in N/mm²

$$n = n_0 \cdot n_{90}$$

n = number of reinforcing screws

n_0 = number of reinforcing screws arranged in a row parallel to the grain

n_{90} = number of reinforcing screws arranged in a row perpendicular to the grain

Simpson Strong-Tie® screws



Annex 9

of European Technical Assessment
 ETA-13/0796 of 15.12.2017

Characteristic data of the screws

- $l_{ef,2}$ = effective contact length in the plane of the screw tips in mm
- $l_{ef,2} = \{l_{ef} + (n_0 - 1) \cdot a_1 + \min(l_{ef}; a_{1,c})\}$ end supports
- $l_{ef,2} = \{2 \cdot l_{ef} + (n_0 - 1) \cdot a_1\}$ intermediate supports
- l_{ef} = penetration length of the threaded part of the screw in the timber member in mm
- $a_{1,c}$ = end distance of the centre of gravity of the threaded part in the timber member in mm

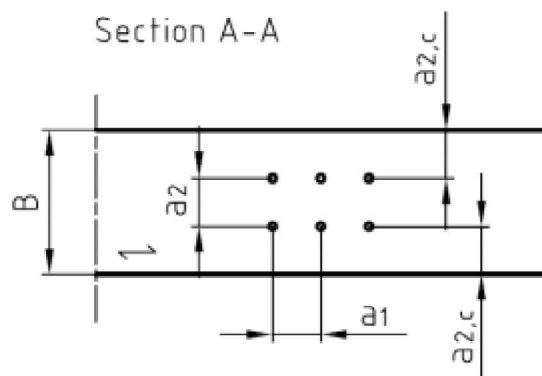
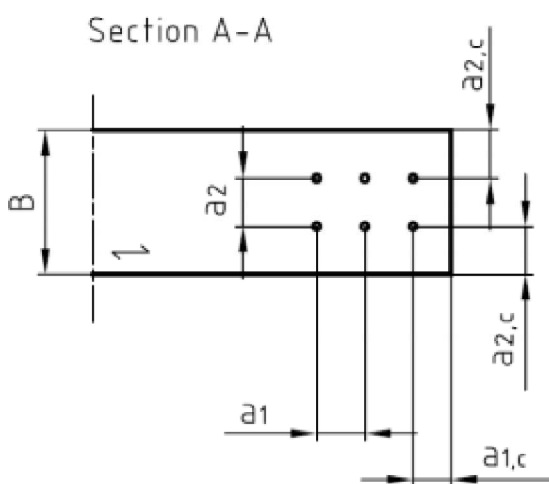
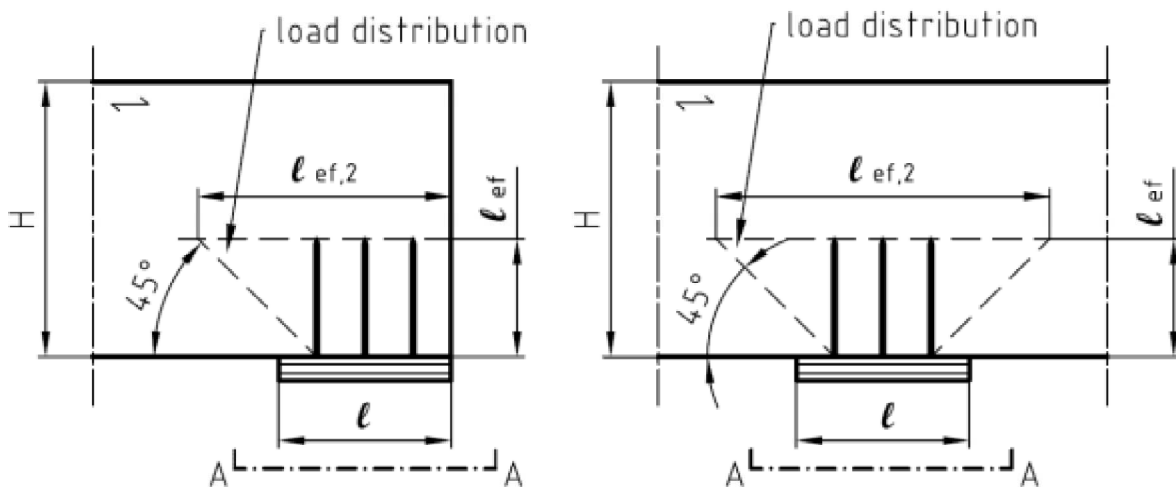

Simpson Strong-Tie® screws



Characteristic data of the screws

Annex 9

of European Technical Assessment
 ETA-13/0796 of 15.12.2017

A.9.7 Tensile reinforcement perpendicular to the grain

Fully threaded screws may be used as tensile reinforcement perpendicular to the grain of the timber members. The screws are driven into the timber member under an angle between the screw axis and the grain direction of 90°. A minimum of two screws shall be used for tensile reinforcement perpendicular to the grain. Only one screw may be used when the minimum penetration depth of the screws below and above the potential crack is $20 \cdot d$ where d is the outer thread diameter of the screw.

Tension reinforcement for transverse connections and notches may be designed according to

$$\left[1 - 3 \cdot \alpha^2 + 2 \cdot \alpha^3\right] \cdot F_{90} \leq F_{ax,Rd} \quad \text{for transverse connections with } \alpha = \frac{a}{h}$$

$$1.3 \cdot V_d \cdot \left[3 \cdot (1 - \alpha)^2 - 2 \cdot (1 - \alpha)^3\right] \leq F_{ax,Rd} \quad \text{for notches with } \alpha = \frac{h_e}{h}$$

where

$$F_{ax,Rd} = \min \left\{ \begin{array}{l} f_{ax,d} \cdot d \cdot l_2 \\ F_{t,Rd} \end{array} \right. \quad \text{axial capacity of the reinforcement in N}$$

F_{90} = design value of the force acting in the connection perpendicular to the grain of the timber members in N

V_d = design value of the shear force in N

$f_{ax,d}$ = design value of the withdrawal capacity of the threaded part of the screw in N/mm²

l_2 = smaller value of the penetration depth below or above the potential crack ($l_{2,a}$ or $l_{2,t}$) in mm

$F_{t,Rd}$ = design value of the tensile resistance of the screw in N

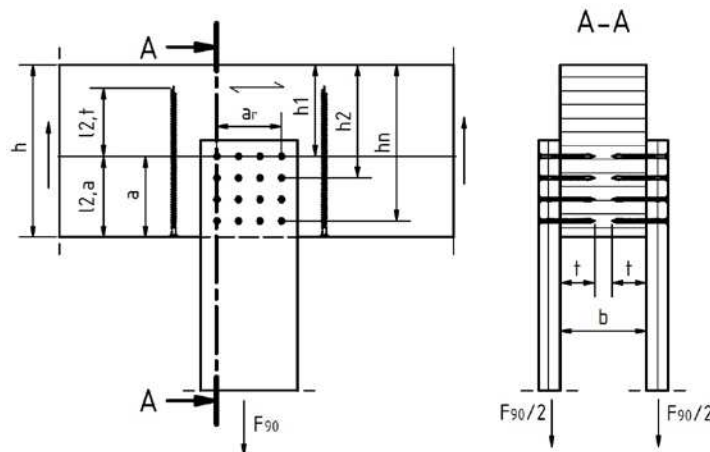

Simpson Strong-Tie® screws



Annex 9

of European Technical Assessment
 ETA-13/0796 of 15.12.2017

Characteristic data of the screws

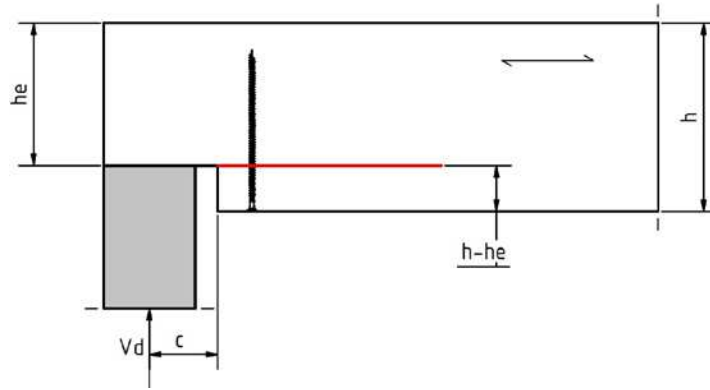

Tension reinforcement of openings may be designed according to

$$F_{t,V,d} + F_{t,M,d} \leq F_{ax,d}$$

where

$$F_{t,V,d} = \frac{V_d \cdot h_d}{4 \cdot h} \cdot \left(3 - \frac{h_d^2}{h^2} \right)$$

$F_{t,V,d}$ = design value of tension force perpendicular to the grain due to lateral force in N

$$F_{t,M,d} = 0.008 \cdot \frac{M_d}{h_r}$$

$F_{t,M,d}$ = design value of tension force perpendicular to the grain due to bending moment in N

V_d = design value of the lateral force in the edge of the opening in N

h = height of the timber member in mm

h_d = height of the opening for rectangular openings or 70 % of opening diameter for circular openings in mm

M_d = design value of bending moment in the edge of the opening in Nmm

h_r = min (h_{ro} ; h_{ru}) for rectangular openings or min ($h_{ro} + 0.15 h_d$; $h_{ru} + 0.15 h_d$) for circular openings in mm

$F_{ax,d}$ = design load bearing capacity for the screws perpendicular to the grain with l_{ef} as the smaller length above or below the potential crack in N

Simpson Strong-Tie® screws



Annex 9

of European Technical Assessment
 ETA-13/0796 of 15.12.2017

Characteristic data of the screws

A.9.8 Shear reinforcement

Fully threaded screws may be used as shear reinforcement of solid timber, glued laminated timber and glued solid timber of softwood. The provisions are valid for straight beams with constant rectangular cross-section. The screws are driven into the timber member under an angle between the screw axis and the grain direction of 45°.

A minimum of four screws shall be used for shear reinforcement in a line parallel to the grain whereas the spacing between the screws shall not exceed the depth h of the timber member. If the screws are arranged in one line parallel to the grain, it shall be done centrally in relation to the beam width.

The effect of the reinforcement is limited to the shaded part of the timber member. Outside this area sufficient shear strength of the cross section must be verified.

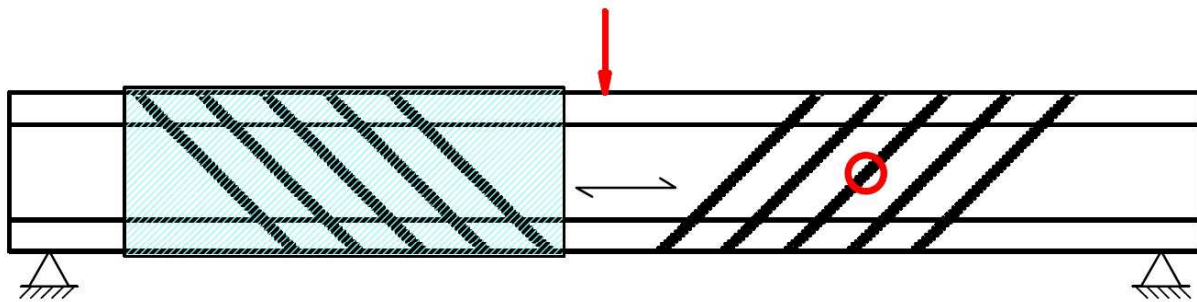

Shear reinforcement may be designed according to

$$\tau_d \leq \frac{f_{v,d} \cdot k_\tau}{\eta_H}$$

where

τ_d = design value of shear stress in N/mm²

$f_{v,d}$ = design value of shear strength in N/mm²

$$k_\tau = 1 - 0.46 \cdot \sigma_{90,d} - 0.052 \cdot \sigma_{90,d}^2$$

$$\sigma_{90,d} = \frac{F_{ax,d}}{\sqrt{2} \cdot b \cdot a_1} \quad \text{design value of stress perpendicular to the grain in N/mm}^2$$

b = width of the timber member in mm

a_1 = spacing of screws parallel to the grain in mm

$$F_{ax,d} = \frac{\sqrt{2} \cdot (1 - \eta_H) \cdot V_d \cdot a_1}{h}$$

V_d = design shear force in N

Simpson Strong-Tie® screws



Annex 9

of European Technical Assessment
 ETA-13/0796 of 15.12.2017

Characteristic data of the screws

h = height of the timber member in mm

$$\eta_H = \frac{G \cdot b}{G \cdot b + \frac{1}{2 \cdot \sqrt{2} \left(\frac{6}{\pi \cdot d \cdot h \cdot k_{ax}} + \frac{a_1}{EA_S} \right)}}$$

G = mean value of shear modulus of the timber member in N/mm²

d = outer thread diameter of the screw in mm

k_{ax} = connection stiffness between screw and timber member in N/mm³,
 $k_{ax} = 12.5$ N/mm³ for Simpson Strong-Tie® fully threaded screws
 ESCRFT/ESCRFT-S, ESCRFTZ/ESCRFTZ-S, ESCRFTC/ESCRFTC-S and
 SSTA with $d = 8$ mm

$$EA_S = \frac{E \cdot \pi \cdot d_1^2}{4} \quad \text{axial stiffness of one screw in N}$$

d_1 = inner thread diameter of the screw in mm

The axial capacity of the screw shall fulfill

$$\frac{F_{ax,d}}{F_{ax,Rd}} \leq 1$$

where

$$F_{ax,Rd} = \min \left\{ \begin{array}{l} f_{ax,d} \cdot d \cdot l_{ef} \\ f_{tens,d} \end{array} \right.$$

$f_{ax,d}$ = design value of the withdrawal parameter of the threaded part of the screw in N/mm²

l_{ef} = effective penetration length with 50 % of the threaded part length of the screw in the timber member in mm

$f_{tens,d}$ = design tensile strength of the screw in N

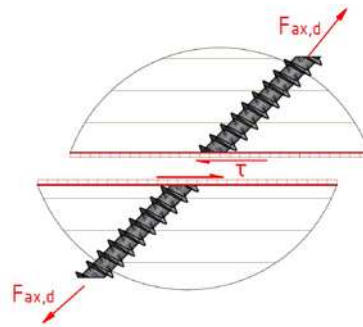

Simpson Strong-Tie® screws



Characteristic data of the screws

Annex 9

of European Technical Assessment
 ETA-13/0796 of 15.12.2017

A.11.1 Fastening of thermal insulation material (on top of rafters and facades)

Simpson Strong-Tie® screws with an outer thread diameter of at least 6 mm and lengths between 120 mm and 600 mm may be used for fixing of thermal insulation material on roof constructions of timber or on wood-based members in vertical facades. Cylinder heads (see Annex 4 and Annex 6) are excluded from fixing wood-based panels on rafters with thermal insulation material as interlayer.

The angle between grain direction and screw axis shall be $30^\circ \leq \alpha \leq 90^\circ$.

The thickness of the **thermal insulation material** is max. 400 mm. The thermal insulation material shall be applicable as insulation on top of rafters according to national provisions that apply at the installation site.

The **battens** are made from solid timber strength class C24 according to EN 338 and EN 14081-1. The minimum thickness and width of the battens is:

Table A11.1 Minimum thickness and width of the battens

Screw diameter d in mm	b_{min}	t_{min}
	mm	mm
≤ 8	50	30
10	60	40
12	80	50

Instead of battens the following **wood-based panels** may be used to cover the thermal insulation material if they are suitable for that use:

- Plywood according to EN 636 and EN 13986,
- Oriented Strand Board, OSB according to EN 300 and EN 13986,
- Particleboard according to EN 312 and EN 13986
- Fibreboards according to EN 622-2, EN 622-3 and EN 13986.

The minimum thickness of the wood-based panels shall be 22 mm.

The word batten in the following includes the meaning of the above mentioned wood-based panels.

The **substructure** is made from solid timber strength class C24 according to EN 338 and EN 14081-1, cross laminated timber according to European Technical Assessments or laminated veneer lumber according to EN 14374. The minimum width is $b_{min} = 60$ mm, for screws with an outer thread diameter of 12 mm the minimum width $b_{min} = 80$ mm.

The spacing between screws e_s shall be not more than 1.75 m.

<p>Simpson Strong-Tie® screws</p> 	<p>Annex 11 of European Technical Assessment ETA-13/0796 of 15.12.2017</p>
<p>Fastening of thermal insulation material</p>	

electronic copy

Version 1

roof, facade
 $\beta = 0^\circ - 90^\circ$

A: acc. to static
 B: $\leq 50\text{mm}$

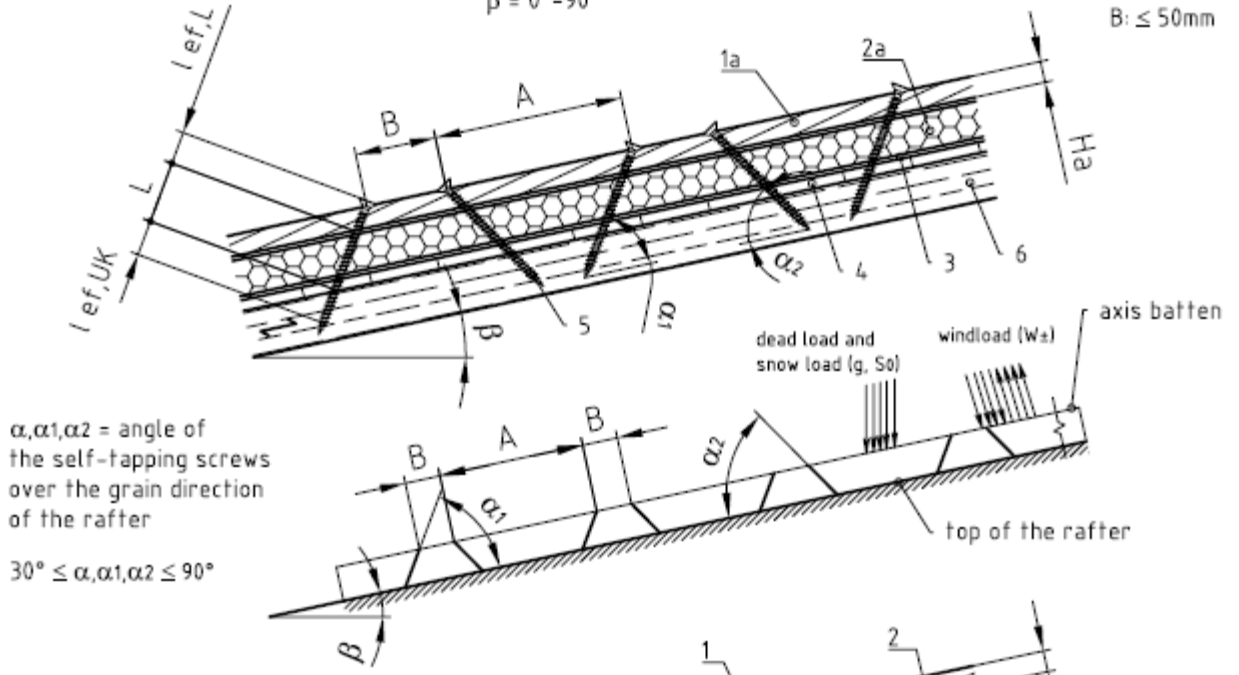

$\alpha, \alpha_1, \alpha_2$ = angle of the self-tapping screws over the grain direction of the rafter
 $30^\circ \leq \alpha, \alpha_1, \alpha_2 \leq 90^\circ$

Version 2

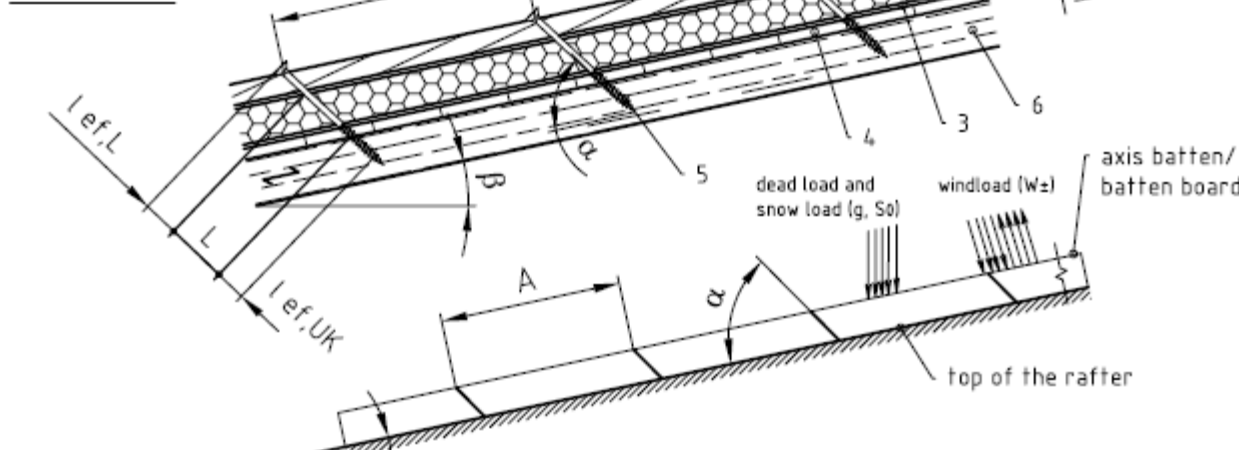

Legende:

- | | |
|---|--|
| 1 batten/batten board | A distance of the screws |
| 1a batten | H thickness batten/batten board |
| 2 heat insulation (till 300mm), pressure resistant (min. 0,05 N/mm ²) | Ha thickness batten |
| 2a heat insulation (till 400mm), pressure resistant | l ef,L penetration lenght in the batten/batten board |
| 3 vapour barrier | l ef,UK penetration lenght in the rafter |
| 4 roof boards | |
| 5 self-tapping screws | |
| 6 rafter | |

Simpson Strong-Tie® screws



Annex 11

of European Technical Assessment
 ETA-13/0796 of 15.12.2017

Fastening of thermal insulation material

A.11.2 Alternately inclined screws (only screws with full thread)

The screws are predominantly loaded in withdrawal or compression, respectively. Only systems with battens are allowed.

Design

For design of thermal insulation systems in terms of number and spacing of the screws the following characteristic values of tensile or compressive load bearing capacity may be taken into account:

$$R_{ax,k} = \min \left\{ \begin{array}{l} f_{ax,k,\alpha} \cdot d \cdot l_{ef,L} \\ f_{ax,k,\alpha} \cdot d \cdot l_{ef,UK} \end{array} \right. \quad \text{in N}$$

where:

- $f_{ax,k,\alpha}$ = characteristic value of the axial withdrawal parameter of the threaded part of the screw in the batten, $f_{ax,k,\alpha}$ does not apply for wood-based panels
- α = angle between screw axis and grain direction of batten or substructure
- d = outer thread diameter of the screw in mm
- $l_{ef,L}$ = penetration length of the threaded part of the screw in the batten in mm; the screw head length k may be taken into account for tension load (not for compressive loading)
- $l_{ef,UK}$ = penetration length of the threaded part of the screw in the substructure in mm; ≥ 60 mm

For compressive loading the design compressive load bearing capacity shall not exceed the buckling capacity of the screws $\chi \cdot N_{pl,d}$ according to A.9.5.

A.11.3 Parallel inclined screws

The screws are predominantly loaded in tension whereas corresponding thermal insulation material is loaded in compression. The minimum compression stress of the thermal insulation material at 10 % deformation, measured according to EN 826, shall be $\sigma_{(10\%)} \geq 0.05$ N/mm². Hereby systems with battens or wood-based panels may be used.

Design

For design of thermal insulation systems in terms of number and spacing of the screws the following characteristic withdrawal parameter may be taken into account:

<p style="text-align: center;">Simpson Strong-Tie® screws</p> 	<p style="text-align: center;">Annex 11</p> <p style="text-align: center;">of European Technical Assessment ETA-13/0796 of 15.12.2017</p>
<p style="text-align: center;">Fastening of thermal insulation material</p>	

electronic copy

European Assessment Document EAD 130118-00-0603 “Screws for use in timber constructions”

EN 300 (07.2006), Oriented Strand Boards (OSB) – Definitions, classification and specifications

EN 312 (09.2010), Particleboards – Specifications

EN 338 (04.2016), Structural timber – Strength classes

EN 622-2 (04.2004) +AC (12.2005), Fibreboards – Specifications – Part 2: Requirements for hardboards

EN 622-3 (04.2004), Fibreboards – Specifications – Part 3: Requirements for medium boards

EN 634-1 (03.1995), Cement-bonded particleboards – Specifications – Part 1: General requirements

EN 636 (03.2015), Plywood – Specifications

EN 826 (03.2013), Thermal insulating products for building applications – Determination of compression behaviour

EN 1993-1-4 (10.2006) +A1 (06.2015), Eurocode 3 – Design of steel structures – Part 1-4: General rules – Supplementary rules for stainless steels

EN 1995-1-1 (11.2004), +AC (6.2006), +A1 (06.2008), +A2 (05.2014), Eurocode 5 – Design of timber structures – Part 1-1: General – Common rules and rules for buildings

EN 10088-1 (10.2014), Stainless steels – Part 1: List of stainless steels

EN 13353:2008+A1 (05.2011), Solid wood panels (SWP) – Requirements

EN 13986:2004+A1 (04.2015), Wood-based panels for use in construction - Characteristics, evaluation of conformity and marking

EN 14080 (06.2013), Timber structures – Glued laminated timber and glued solid timber – Requirements

EN 14081-1 (02.2016), Timber structures – Strength graded structural timber with rectangular cross section – Part 1: General requirements

EN 14374 (11.2004), Timber structures – Structural laminated veneer lumber – Requirements

Simpson Strong-Tie® screws



Annex 12

of European Technical Assessment
 ETA-13/0796 of 15.12.2017

Reference documents